

NordicTrack[®] **VIEWPOINT 2800**

Model No. NTL14905.3

Serial No. _____

Find the serial number in the location shown below. Write the serial number in the space above for reference.

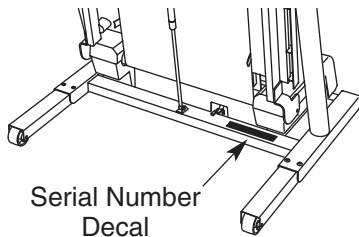

QUESTIONS?

As a manufacturer, we are committed to providing complete customer satisfaction. If you have questions, or if parts are damaged or missing, PLEASE CONTACT OUR CUSTOMER SERVICE DEPARTMENT DIRECTLY.

CALL TOLL-FREE:

1-888-825-2588

Mon.–Fri., 6 a.m.–6 p.m. MST

ON THE WEB:

www.nordictrackservice.com

USER'S MANUAL

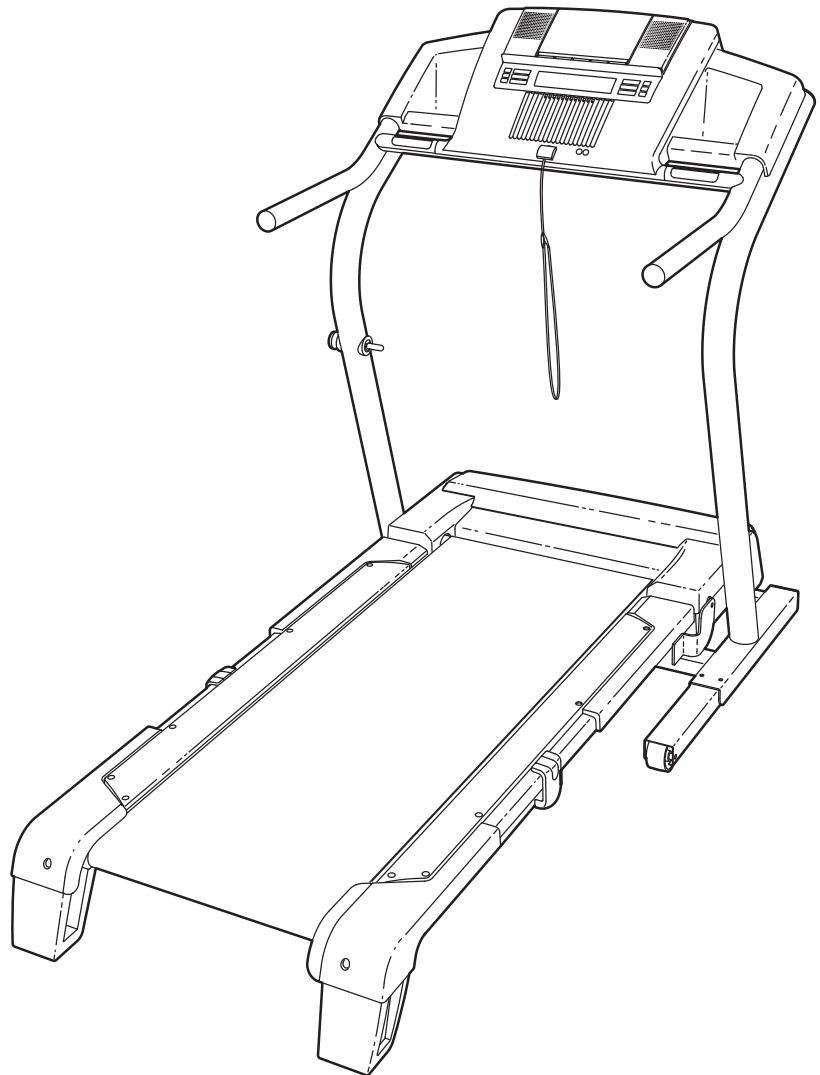

CAUTION

Read all precautions and instructions in this manual before using this equipment. Save this manual for future reference.



Visit our website at

www.nordictrack.com

new products, prizes,
fitness tips, and much more!



TABLE OF CONTENTS

IMPORTANT PRECAUTIONS3
BEFORE YOU BEGIN6
ASSEMBLY7
OPERATION AND ADJUSTMENT13
HOW TO FOLD AND MOVE THE TREADMILL32
TROUBLESHOOTING34
CONDITIONING GUIDELINES37
PART LIST38
ORDERING REPLACEMENT PARTS39
LIMITED WARRANTYBack Cover

Note: An EXPLODED DRAWING is attached in the center of this manual.

IMPORTANT PRECAUTIONS

⚠ WARNING: To reduce the risk of burns, fire, electric shock, or injury to persons, read the following important precautions and information before operating the treadmill.

1. It is the responsibility of the owner to ensure that all users of this treadmill are adequately informed of all warnings and precautions.
2. Use the treadmill only as described.
3. Place the treadmill on a level surface, with at least eight feet of clearance behind it and two feet on each side. Do not place the treadmill on any surface that blocks air openings. To protect the floor or carpet from damage, place a mat under the treadmill.
4. Keep the treadmill indoors, away from moisture and dust. Do not put the treadmill in a garage or covered patio, or near water.
5. Do not operate the treadmill where aerosol products are used or where oxygen is being administered.
6. Keep children under the age of 12 and pets away from the treadmill at all times.
7. The treadmill should not be used by persons weighing more than 350 pounds.
8. Never allow more than one person on the treadmill at a time.
9. Wear appropriate exercise clothes when using the treadmill. Do not wear loose clothes that could become caught in the treadmill. Athletic support clothes are recommended for both men and women. *Always wear athletic shoes. Never use the treadmill with bare feet, wearing only stockings, or in sandals.*
10. When connecting the power cord (see page 13), plug the power cord into a surge suppressor (not included) and plug the surge suppressor into a grounded circuit capable of carrying 15 or more amps. No other appliance should be on the same circuit. Do not use an extension cord.
11. Use only a single-outlet surge suppressor that meets all of the specifications described on page 13. To purchase a surge suppressor, see your local NordicTrack dealer or call the toll-free telephone number on the front cover of this manual and order part number 146148, or see your local electronics store.
12. Failure to use a properly functioning surge suppressor could result in damage to the control system of the treadmill. If the control system is damaged, the walking belt may change speed, accelerate, or stop unexpectedly, which may result in a fall and serious injury.
13. Keep the power cord and the surge suppressor away from heated surfaces.
14. Never move the walking belt while the power is turned off. Do not operate the treadmill if the power cord or plug is damaged, or if the treadmill is not working properly. (See TROUBLESHOOTING on page 34 if the treadmill is not working properly.)
15. Read, understand, and test the emergency stop procedure before using the treadmill (see OPERATION AND ADJUSTMENT on page 13).
16. Never start the treadmill while you are standing on the walking belt. Always hold the handrails while using the treadmill.
17. The treadmill is capable of high speeds. Adjust the speed in small increments to avoid sudden jumps in speed.
18. The pulse sensor is not a medical device. Various factors, including the user's movement, may affect the accuracy of heart rate readings. The pulse sensor is intended only as an exercise aid in determining heart rate trends in general.
19. Never leave the treadmill unattended while it is running. Always remove the key, unplug the power cord, and switch the reset/off circuit breaker to the "off" position when the treadmill is not in use. (See the drawing on page 6 for the location of the reset/off circuit breaker.)
20. Do not attempt to raise, lower, or move the treadmill until it is properly assembled. (See ASSEMBLY on page 7, and HOW TO FOLD AND MOVE THE TREADMILL on page 32.) You must be able to safely lift 45 pounds (20 kg) to raise, lower, or move the treadmill.

21. Do not change the incline of the treadmill by placing objects under the treadmill.
22. When folding or moving the treadmill, make sure that the frame is held securely by the pin on the latch knob.
23. When using iFIT programs, an electronic “chirping” sound will alert you when the speed and/or incline of the treadmill is about to change. Always listen for the “chirp” and be prepared for speed and/or incline changes. In some instances, the speed and/or incline may change before the personal trainer describes the change.
24. When using iFIT programs, you can manually override the speed and incline settings by pressing the speed and incline buttons. However, when the next “chirp” is heard, the speed and/or incline will change to the next settings of the program.
25. Always remove iFIT CDs and videos from your CD player or VCR and disconnect your MP3 player when you are not using them.
26. Inspect and properly tighten all parts of the treadmill regularly.
27. Never insert or drop any object into any opening.
28. **DANGER:** Always unplug the power cord immediately after use, before cleaning the treadmill, and before performing the maintenance and adjustment procedures described in this manual. Never remove the motor hood unless instructed to do so by an authorized service representative. Servicing other than the procedures in this manual should be performed by an authorized service representative only.
29. The treadmill is intended for in-home use only. Do not use the treadmill in any commercial, rental, or institutional setting.
30. If an outside antenna or cable system is connected, be sure that the antenna or cable system is grounded to provide some protection against voltage surges and built-up static charges. Section 810 of the National Electrical Code, ANSI/NFPA No. 70-1984, pro-

vides information with respect to proper grounding of the mast and supporting structure, grounding of the lead-in wire to an antenna discharge unit, size of grounding conductors, location of antenna discharge unit, connection to grounding electrodes, and requirements for the grounding electrode.

31. An outside antenna system should not be located in the vicinity of overhead power lines or other electric light or power circuits, or where it can fall into such power lines or circuits. When installing an outside antenna system, extreme care should be taken to keep from touching such power lines or circuits, as contact with them might be fatal.
32. To reduce the risk of electric shock, do not remove the cover or the back of the television. There are no user serviceable parts inside. Refer servicing to qualified service personnel.
33. Upon completion of any service or repairs to the treadmill or the television, ask the service technician to perform safety checks to confirm that the unit is in proper operating condition.
 - Use No. 10 AWG (5.3mm²) copper, No. 8 AWG (8.4mm²) aluminum, No. 17 AWG (1.0mm²) copper-clad steel or bronze wire, or larger as a ground wire.
 - Secure an antenna lead-in and ground wires to the house with stand-off insulators spaced from 4 to 6 feet (1.22 to 1.83m) apart.
 - Mount an antenna discharge unit as close as possible to where the lead-in enters the house.
 - Use a jumper wire not smaller than No. 6 AWG (13.3mm²) copper, or the equivalent when a separate antenna-grounding electrode is used. See NEC Section 810-21 (j).

Note to CATV system installer: This reminder is provided to call the CATV system installer’s attention to Article 820-40 of the NEC that provides guidelines for proper grounding and, in particular, specifies that the cable ground shall be connected to the grounding system of the building, as close to the point of cable entry as practical.

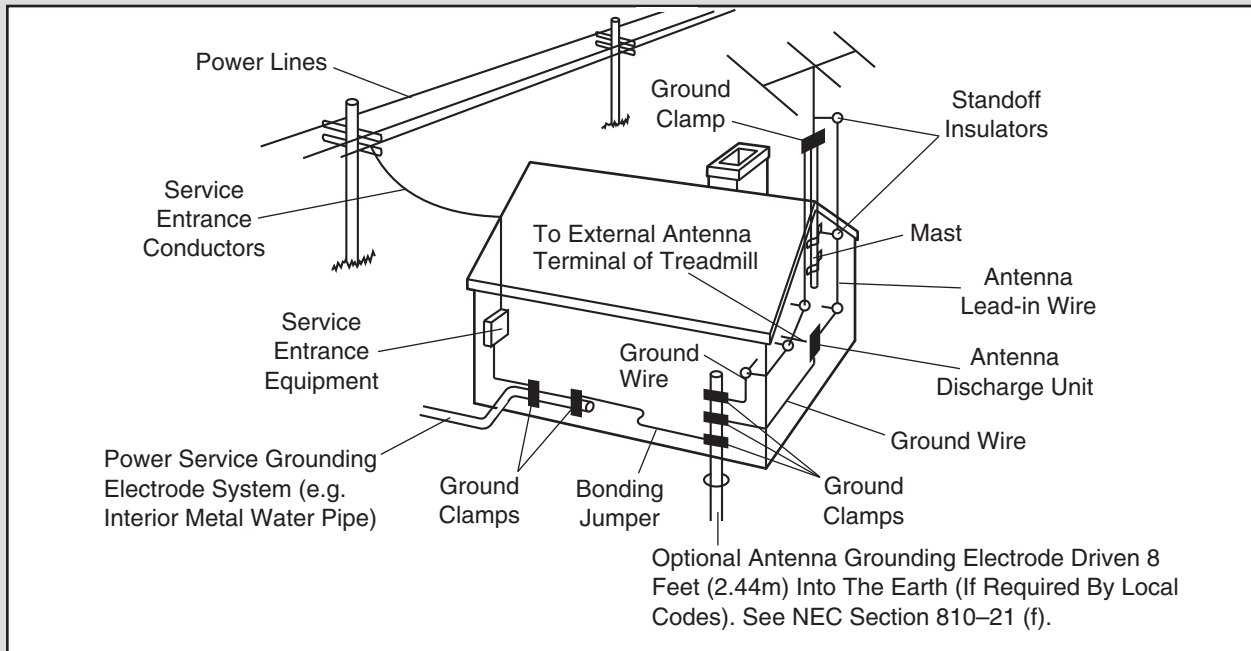



⚠️ WARNING: Before beginning this or any exercise program, consult your physician. This is especially important for persons over the age of 35 or persons with pre-existing health problems. Read all instructions before using. ICON assumes no responsibility for personal injury or property damage sustained by or through the use of this product.

SAVE THESE INSTRUCTIONS

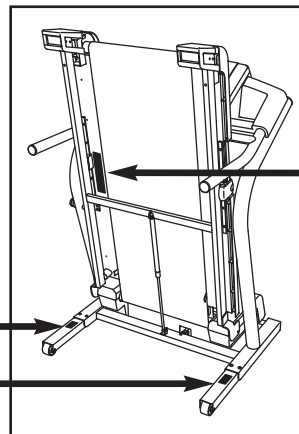
The decals shown here have been placed on the treadmill. If a decal is missing or illegible, call the toll-free telephone number on the front cover of this manual and order a free replacement decal. Apply the decal in the location shown. Note: The decal may not be shown at actual size.



⚠️ WARNING:
Protect yourself and others from risk of serious injury. Read the user's manual and :

-  *Stand only on the side rails when starting or stopping treadmill.
- *Change speed in small increments.
- *Hold handrails to prevent falling, and always wear the safety clip while operating treadmill.
- *Stop if you feel faint, dizzy, or short of breath.
- *Fully engage storage latch before treadmill is moved or stored.
- *Reduce incline to its lowest level before folding treadmill into storage position.
-  *Never allow children on or around treadmill.
- *Remove key when not in use.
-  *Keep clothing, fingers, and hair away from moving belt.
- *Never try to adjust or fix the belt while it is moving.
- *Always wear athletic shoes while operating treadmill.

BEFORE YOU BEGIN

Thank you for selecting the revolutionary NordicTrack® C2800 treadmill. The C2800 treadmill offers an impressive selection of features designed to make your workouts at home more enjoyable and effective. And when you're not exercising, the unique C2800 treadmill can be folded up, requiring less than half the floor space of other treadmills.

For your benefit, read this manual carefully before using the treadmill. If you have questions after read-

ing this manual, please see the front cover of this manual. To help us assist you, please note the product model number and serial number before contacting us. The model number of the treadmill is NTL14905.3. The serial number can be found on a decal attached to the treadmill (see the front cover of this manual for the location).

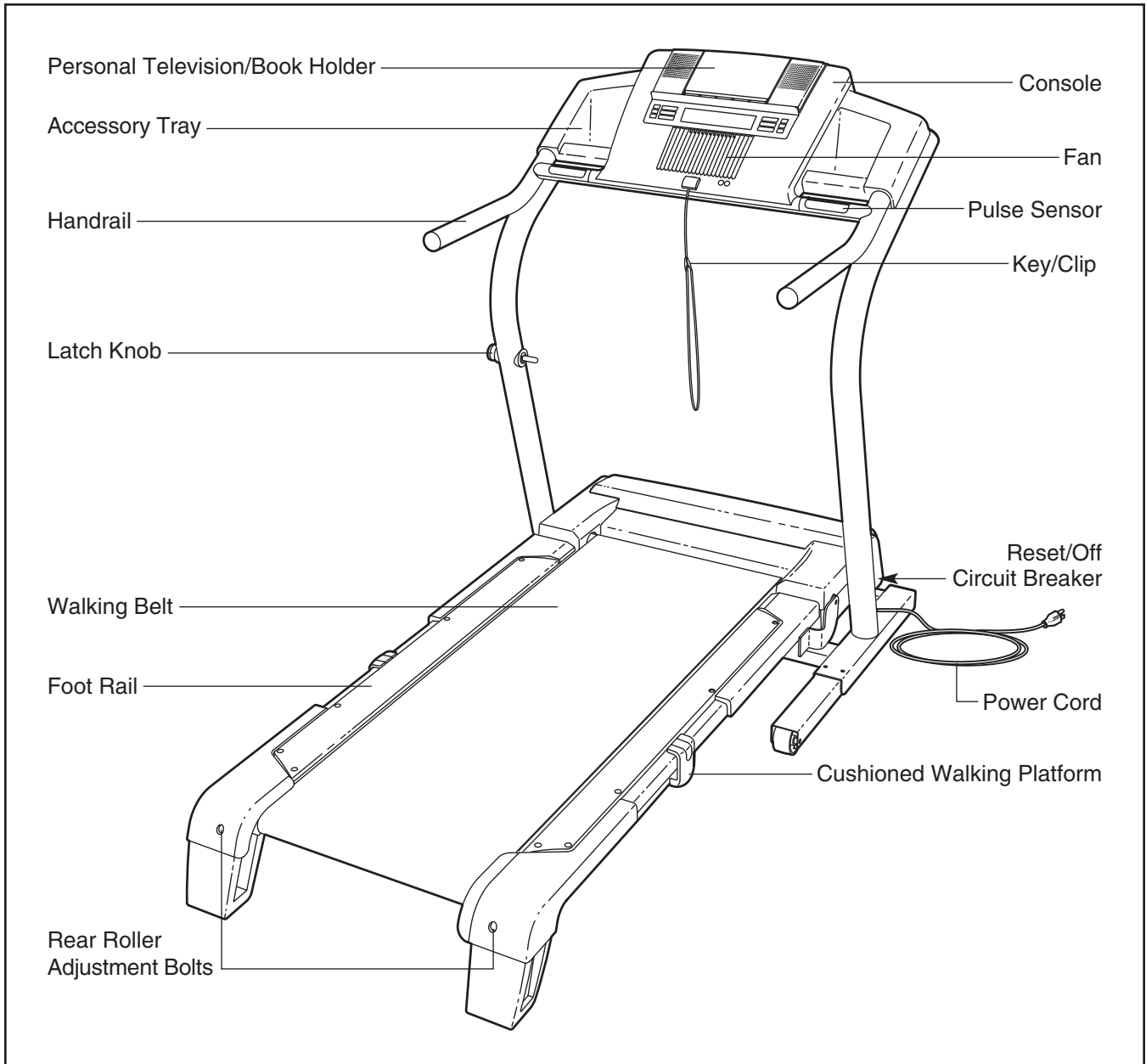

Before reading further, please familiarize yourself with the parts that are labeled in the drawing below.



ASSEMBLY

Assembly requires two persons. Set the treadmill in a cleared area and remove all packing materials. **Do not dispose of the packing materials until assembly is completed.**

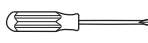
Note: The underside of the treadmill walking belt is coated with high-performance lubricant. During shipping, a small amount of lubricant may be transferred to the top of the walking belt or the shipping carton. This is a normal condition and does not affect treadmill performance. If there is lubricant on top of the walking belt, simply wipe off the lubricant with a soft cloth and a mild, non-abrasive cleaner.

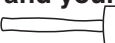
Assembly requires the included allen wrench  **and your own phillips screwdriver** , **adjustable wrench** , **and rubber mallet** . **For help identifying the assembly hardware, see the drawings below.** The number in parentheses below each drawing is the key number of the part, from the PART LIST on pages 38 and 39. The number following the parentheses is the quantity needed for assembly. **Note: Some small parts may have been preassembled. If a part is not in the parts bag, check to see if it has been preassembled. To avoid damaging plastic parts, do not use power tools for assembly.**

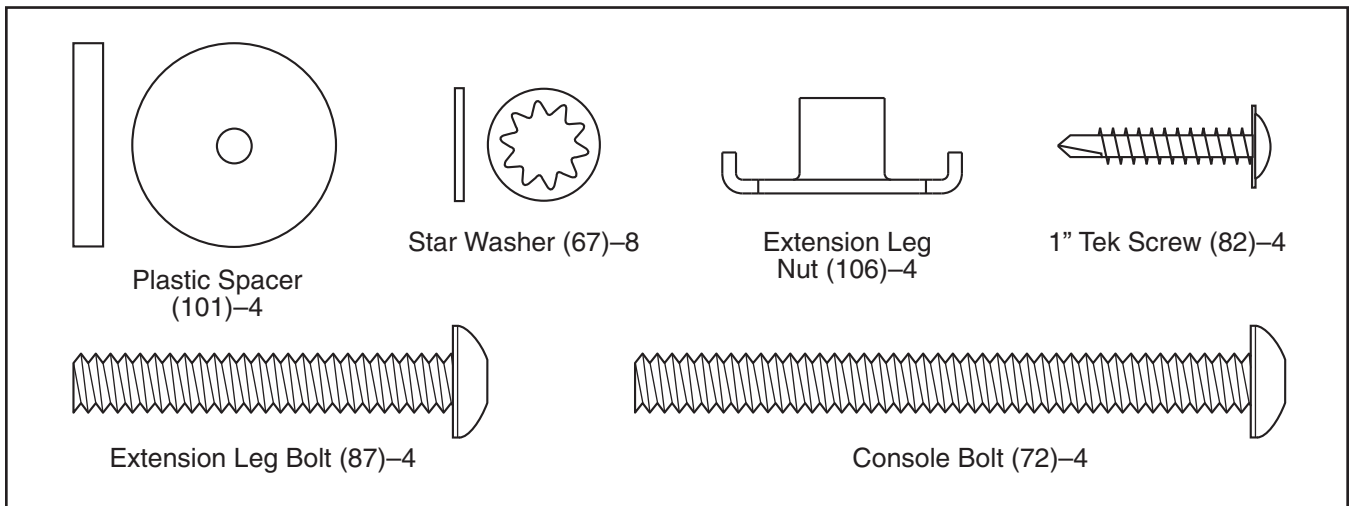

1. Make sure that the power cord is unplugged.

With the help of a second person, carefully tip the treadmill onto its side as shown. Partially fold the Frame (55) so the treadmill is more stable. **Do not fully fold the treadmill until it is completely assembled.**

Orient an Extension Leg (97) so the Base Pad (81) is in the position shown, and insert the Extension Leg into the indicated bracket on the base of the Uprights (85). If necessary, use a rubber mallet to align the holes in the Extension Leg with the holes in the bracket.

Attach the Extension Leg (97) with two Extension Leg Bolts (87), two Star Washers (67), and two Extension Leg Nuts (106) as shown. **Firmly tighten the Extension Leg Bolts.**

With the help of a second person, carefully tip the treadmill onto its other side. Attach the other Extension Leg (97) as described above.

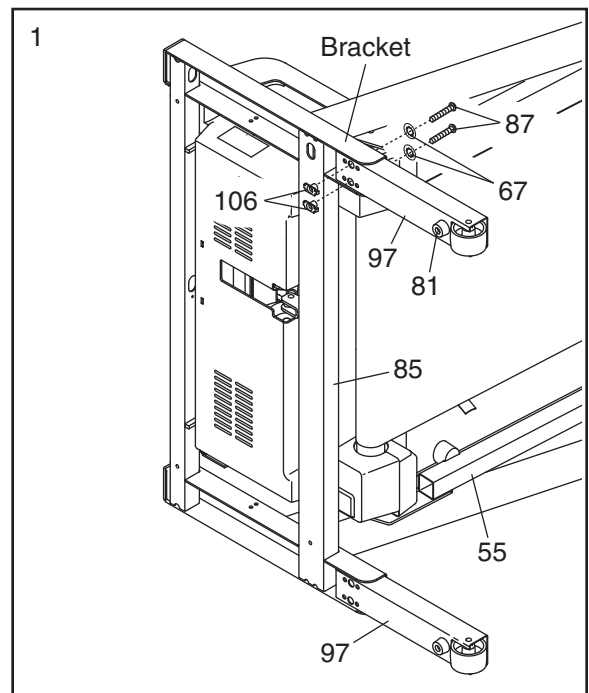

2. Attach the four Base Pads (81) (only three are shown) to the base of the Uprights (85) with four 1" Tek Screws (82) and four Plastic Spacers (101). Note: One replacement Base Pad may be included. Use the Base Pad to replace any Base Pad that becomes worn.

With the help of a second person, carefully tip the treadmill down so the four Base Pads (81) are resting on the floor and the Uprights (85) are in a vertical position.

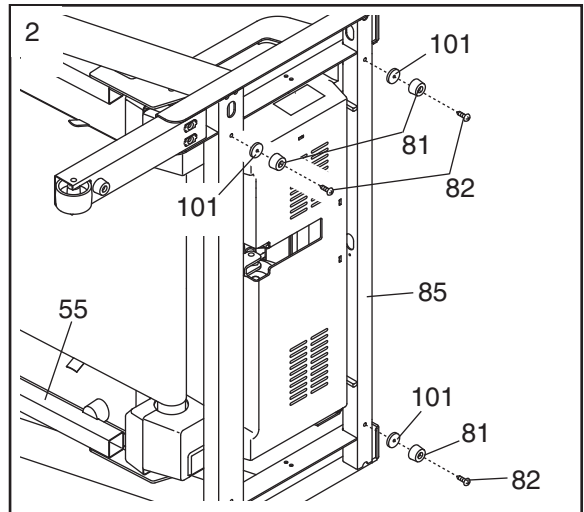

3. Remove the band securing the Upright Wire Harness (73) to the right Upright (85). Have a second person hold the console assembly near the right Upright.

Connect the Upright Wire Harness (73) to the wires extending from the console assembly. **Make sure to connect the connectors properly (see the inset drawing). The connectors should slide together easily and snap into place.** If the connectors do not slide together easily and snap into place, turn one connector and try again. **IF THE CONNECTORS ARE NOT CONNECTED PROPERLY, THE CONSOLE MAY BE DAMAGED WHEN THE POWER IS TURNED ON.** Insert the connectors into the right Upright (85).

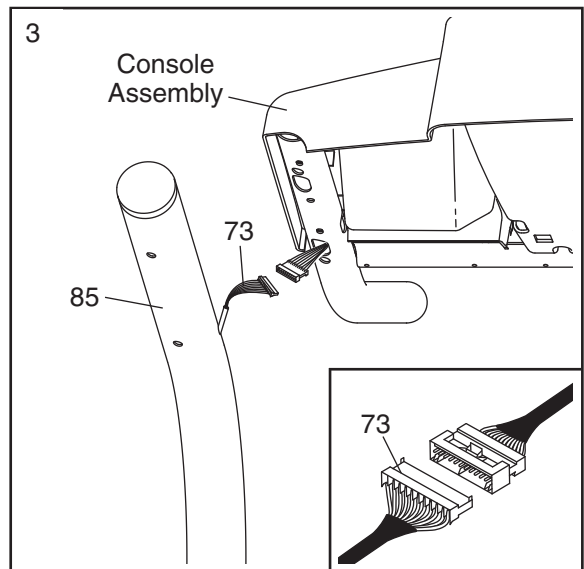

4. Remove the band securing the TV Cable (115) to the left Upright (85). Connect the TV Cable to the cable extending from the console assembly. Then, insert the TV Cable into the left Upright.

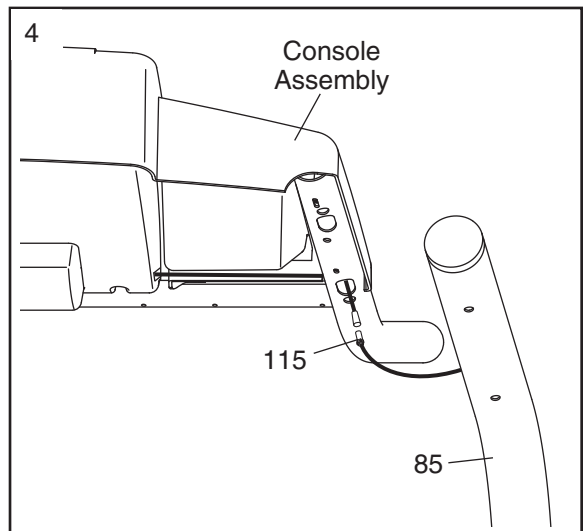

5. With the help of a second person, set the console assembly on the right Upright (85) and the left Upright (not shown). **Make sure that no wires are pinched.** Attach the console assembly with four Console Bolts (72) and four Star Washers (67) (only one side is shown). **Start all four Console Bolts before tightening any of them.**

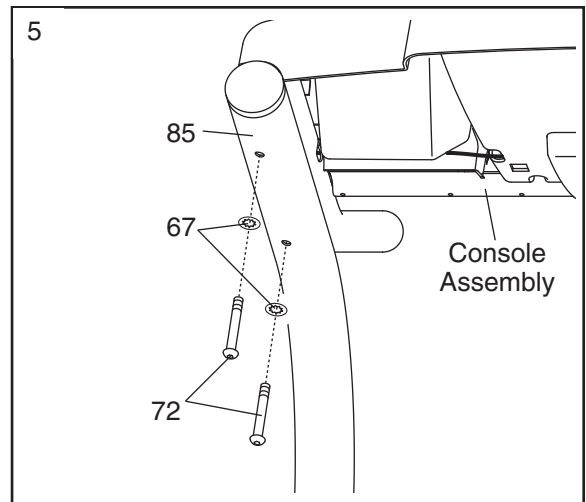

6. Remove the knob from the pin. Make sure that the collar and the spring are on the pin.

Press the Latch Insert (77) into the right side of the left Upright (85). **Make sure that the TV Cable in the left Upright is not pinched by the Latch Insert.** Press the Knob Insert (92) into the left side of the left Upright. Use a rubber mallet, if necessary. Next, insert the pin into the Latch Insert, and tighten the knob back onto the pin.

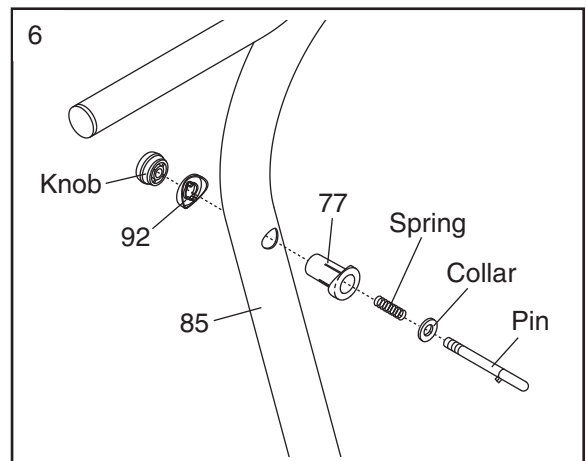

7. Place the treadmill in the storage position (see HOW TO FOLD AND MOVE THE TREADMILL on page 32).

Hold the **cylinder** end of the Shock (114) near the bracket in the center of the crossbar on the Frame (55).

See the two small inset drawings. Using your fingernail or the end of a screwdriver, press on the end of the Shock Clip (108) to loosen it from the Shock (114). Next, rotate the Shock Clip and pull it out of the Shock. **Be careful to avoid losing the Shock Clip.**

Orient the Shock (114) so it is in the position shown. Press the end of the Shock onto the ball on the bracket.

See drawing 7a. Insert the Shock Clip (108) into the two indicated small holes in the end of the Shock (114). Then, rotate the Shock Clip until it clips onto the Shock. Note: Extra Shock Clips are included.

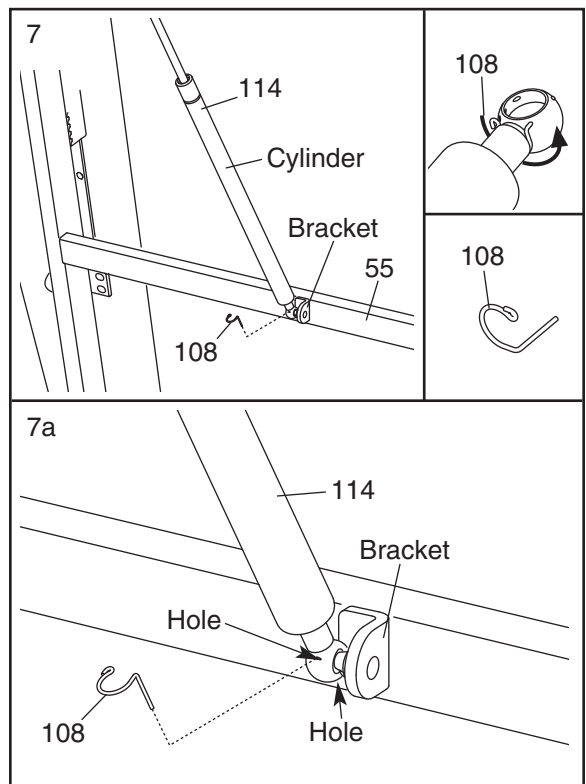

8. Remove the Shock Clip (108) from the lower end of the Shock (114).

Plug in the power cord as described on page 13, and then turn on the power as described on page 15. Next, press the Incline increase and decrease buttons until the ball on the bracket is aligned with end of the Shock (114). Then, press the end of the Shock onto the ball. Note: It may be necessary to press the end of the Shock onto the ball while the Frame (55) is moving.

See drawing 8a. Insert the end of the Shock Clip (108) into two of the small holes in the end of the Shock (114). Then, rotate the Shock Clip until it clips onto the Shock.

Press the Incline decrease button until the treadmill is at the lowest incline level. Unplug the power cord. With the help of a second person, lower the Frame (55) to the floor.

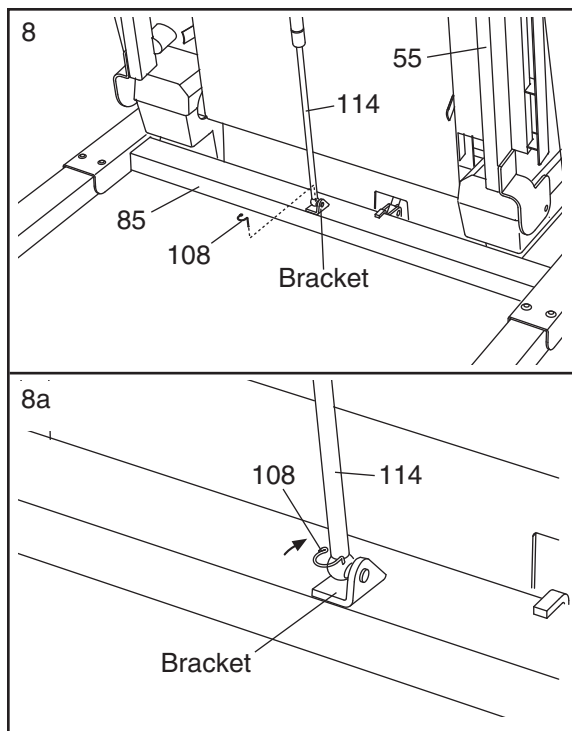

9. **Make sure that all parts are properly tightened before you use the treadmill.** Keep the included allen wrench in a secure place; the allen wrench is used to adjust the walking belt (see page 35). **To protect the floor or carpet from damage, place a mat under the treadmill.**

Before the personal television can be used, you must connect an antenna, a 75 ohm CATV cable, or a VCR to the 75 ohm antenna terminal on the treadmill frame. Note: No antenna, cable, or adapter is included.

HOW TO CONNECT AN ANTENNA

Indoor Antenna

- Place a VHF antenna in the desired location. Connect the 300 ohm flat wire from the antenna to a 300 ohm to 75 ohm adapter.

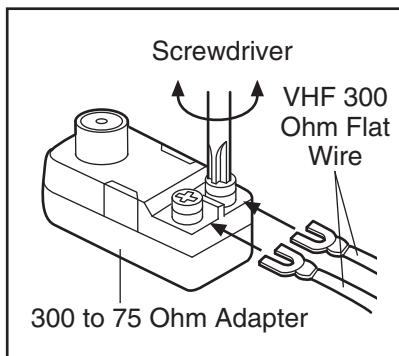

- Push the 300 ohm to 75 ohm adapter onto the 75 ohm antenna terminal on the treadmill frame near the power cord.

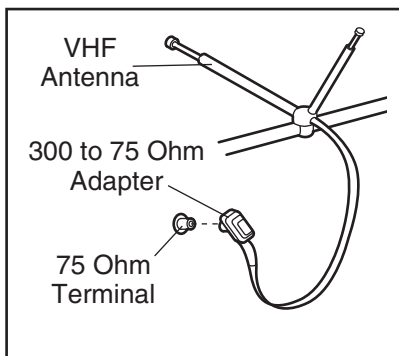

Outdoor Antenna

Note: Outdoor antennas are subject to weathering that can reduce signal quality. Inspect your antenna and the lead-in wiring before connecting the antenna.

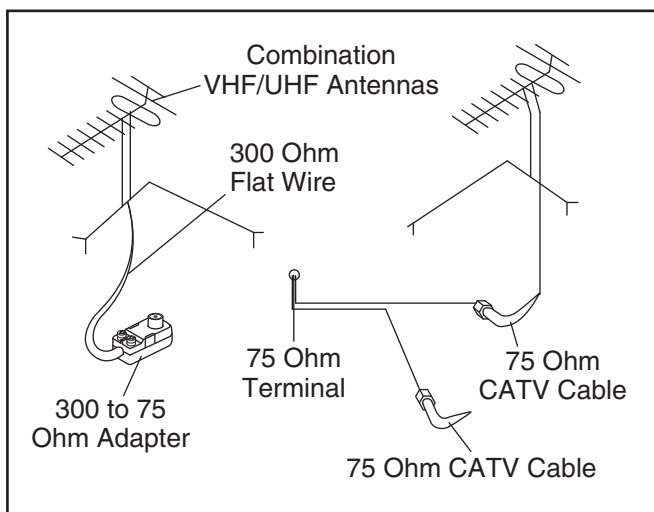

300 Ohm Flat Wire

- See the drawing near the bottom of this page. Connect the 300 ohm flat wire from the antenna to a 300 ohm to 75 ohm adapter.
- Push the 300 ohm to 75 ohm adapter onto the 75 ohm antenna terminal on the treadmill frame near the power cord.

75 Ohm CATV Cable

- See the drawing near the bottom of this page. Connect the 75 ohm CATV cable from the antenna to the 75 ohm antenna terminal on the treadmill frame near the power cord.

HOW TO CONNECT A 75 OHM CATV CABLE

- Connect a 75 ohm CATV cable to the 75 ohm antenna terminal on the treadmill frame near the power cord.

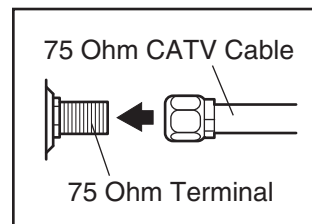

HOW TO CONNECT A VCR

- Connect one end of a 75 ohm CATV cable to the video output jack on your VCR.
- Plug in the power cord of your VCR. See your VCR user's manual for proper grounding instructions.
- Connect the 75 ohm CATV cable to the 75 ohm antenna terminal on the treadmill frame near the power cord.

Note: To operate the television with your VCR, **make sure that channel 3 or 4 is selected.**

If you purchase the optional chest pulse sensor (see page 31), follow the steps below to install the receiver included with the chest pulse sensor.

1. **Make sure that the power cord is unplugged.** Remove the indicated Screws (99) and the two Console Screws (32) from the Console Base (98).

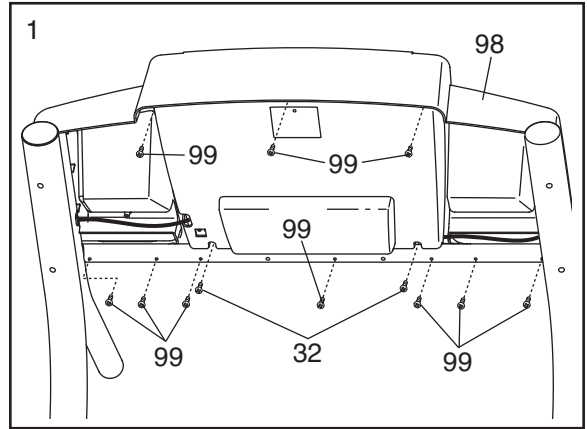

2. Have a second person carefully lift the pulse plates and the Console Base (98). **Be careful not to pull any wires.**

Connect the wire on the receiver (A) to the indicated wire extending from the Console (105). **Hold the receiver so the small cylinder is oriented as shown.** Then, remove the tape from the back of the receiver, and press the receiver onto the Console Base (98) in the location shown.

3. **While making sure that no wires are pinched,** set the Console (105) on the Console Base (98). Place the pulse plates on the Console and the metal crossbar. Reattach the Console and the pulse plates with the Screws (99) and the Console Screws (32) (see step 1). Discard the other wires included with the receiver.

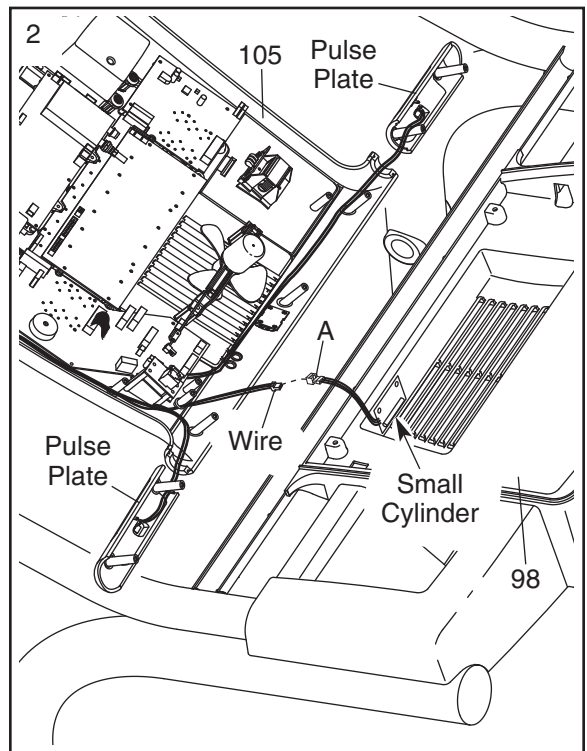

OPERATION AND ADJUSTMENT

THE PRE-LUBRICATED WALKING BELT

Your treadmill features a walking belt coated with high-performance lubricant. **IMPORTANT: Never apply silicone spray or other substances to the walking belt or the walking platform. Such substances will deteriorate the walking belt and cause excessive wear.**

HOW TO PLUG IN THE POWER CORD

⚠ DANGER: Improper connection of the equipment-grounding conductor can result in an increased risk of electric shock. Check with a qualified electrician or serviceman if you are in doubt as to whether the product is properly grounded. Do not modify the plug provided with the product—if it will not fit the outlet, have a proper outlet installed by a qualified electrician.

Your treadmill, like any other type of sophisticated electronic equipment, can be seriously damaged by sudden voltage changes in your home's power. Voltage surges, spikes, and noise interference can result from weather conditions or from other appliances being turned on or off. **To decrease the possibility of your treadmill being damaged, always use a surge suppressor with your treadmill (see drawing 1 at the right).** To purchase a surge suppressor, see your local NordicTrack dealer or call the toll-free telephone number on the front cover of this manual and order part number 146148, or see your local electronics store.

Use only a single-outlet surge suppressor that is UL 1449 listed as a transient voltage surge suppressor (TVSS). The surge suppressor must have a UL suppressed voltage rating of 400 volts or less and a minimum surge dissipation of 450 joules. The surge suppressor must be electrically rated for 120 volts AC and 15 amps. There must be a monitoring light on the surge suppressor to indicate whether it is functioning properly. Failure to use a properly functioning surge suppressor could result in damage to the control system of the treadmill. If the control system is damaged, the walking belt may change speed, accelerate, or stop unexpectedly, which may result in a fall and serious injury.

This product must be grounded. If it should malfunction or break down, grounding provides a path of least resistance for electric current to reduce the risk of elec-

tric shock. This product is equipped with a cord having an equipment-grounding conductor and a grounding plug. **Plug the power cord into a surge suppressor, and plug the surge suppressor into an appropriate outlet that is properly installed and grounded in accordance with all local codes and ordinances. Important: The treadmill is not compatible with GFCI-equipped outlets.**

This product is for use on a nominal 120-volt circuit, and has a grounding plug that looks like the plug illustrated in drawing 1 below. A temporary adapter that looks like the adapter illustrated in drawing 2 may be used to connect the surge suppressor to a 2-pole receptacle as shown in drawing 2 if a properly grounded outlet is not available.

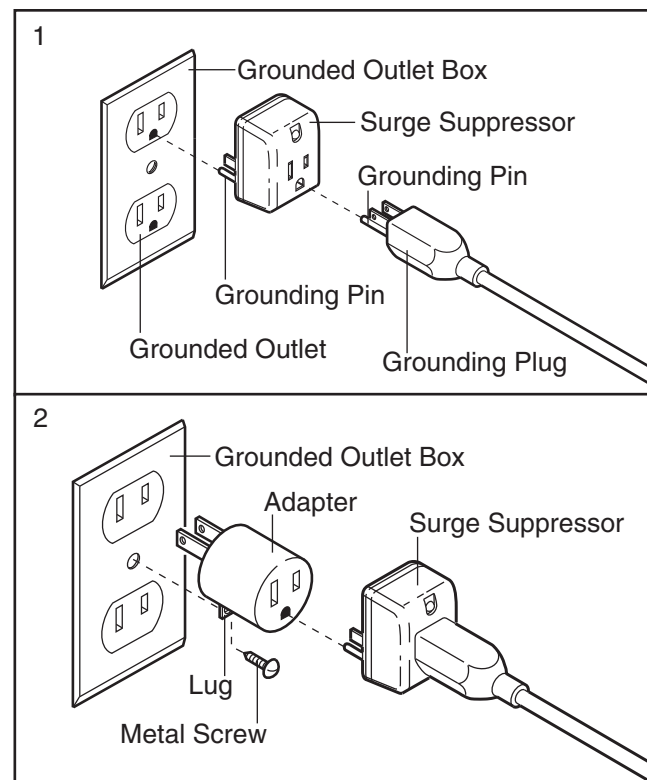

The temporary adapter should be used only until a properly grounded outlet (drawing 1) can be installed by a qualified electrician.

The green-colored rigid ear, lug, or the like extending from the adapter must be connected to a permanent ground such as a properly grounded outlet box cover. Whenever the adapter is used it must be held in place by a metal screw. **Some 2-pole receptacle outlet box covers are not grounded. Contact a qualified electrician to determine if the outlet box cover is grounded before using an adapter.**

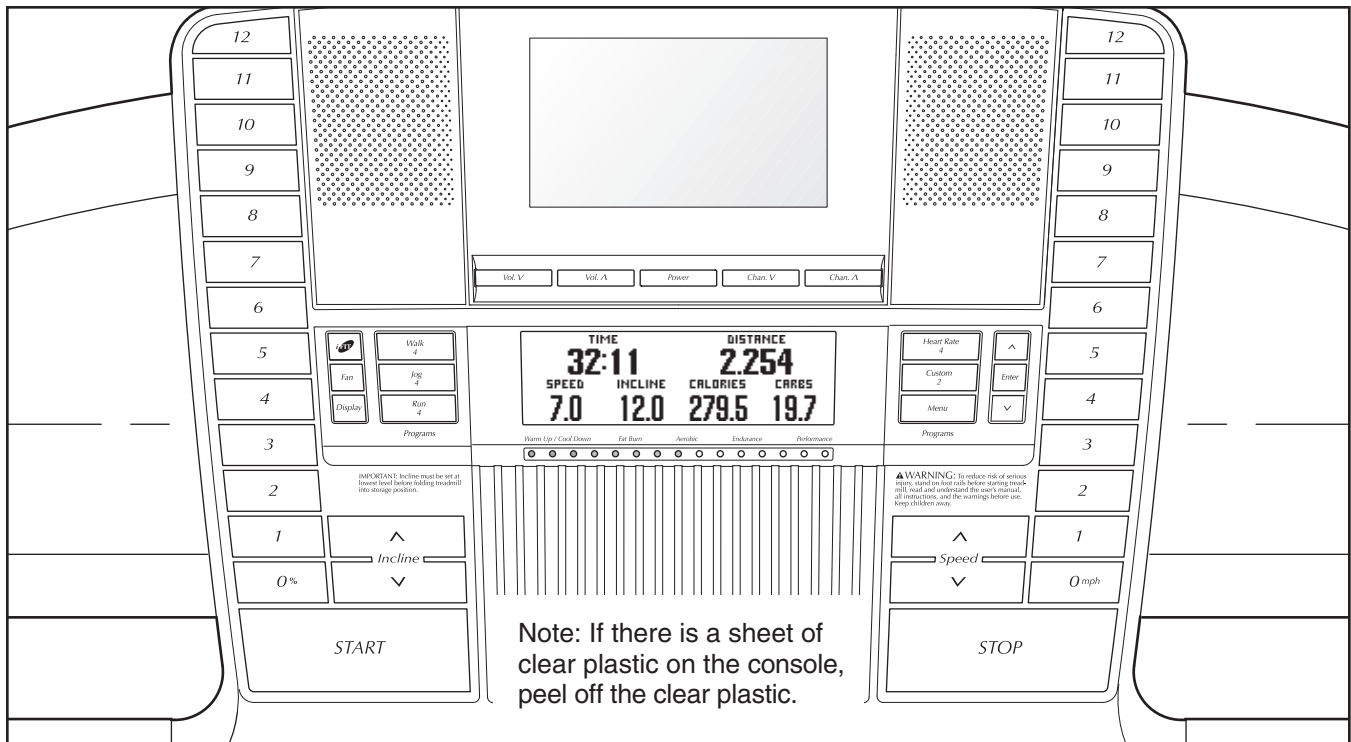

FEATURES OF THE CONSOLE

The treadmill console offers an impressive array of features designed to make your workouts more effective and enjoyable. When the manual mode of the console is selected, the speed and incline of the treadmill can be changed with the touch of a button. As you exercise, the console will display continuous exercise feedback. You can even measure your heart rate using the handgrip pulse sensor or the optional chest pulse sensor (see page 31).

In addition, the console features twelve preset programs—four Walk programs, four Jog programs, and four Run programs. Each program automatically controls the speed and incline of the treadmill as it guides you through an effective workout. You can even create Custom programs and save them for future use. The console also offers four Heart Rate programs that control the speed and incline of the treadmill to help you keep your heart rate near target heart rate settings. Note: The Heart Rate programs require the use of the optional chest pulse sensor.

The console also features iFIT interactive technology. Having iFIT technology is like having a personal trainer in your home. Using a stereo audio cable, you can connect the treadmill to your portable stereo, home stereo, computer, or VCR and play special iFIT MP3, CD, and

video programs (iFIT MP3 programs, CDs, and videocassettes are available separately). iFIT programs automatically control the speed and incline of the treadmill as a personal trainer guides you through every step of your workout; high-energy music provides added motivation. **To purchase and download iFIT MP3 programs, go to www.iFIT.com. To purchase iFIT CDs or videocassettes, call the toll-free telephone number on the front cover of this manual.**

With the treadmill connected to your computer, you can also go to www.iFIT.com and access iFIT programs directly from our Web site. **See www.iFIT.com for more information.**

Whether you select the manual mode or a program, you can enjoy the shows of your choice on the personal television while you get in shape.

To turn on the power, follow the steps on page 15. **To use the main menu of the console**, see page 15. **To use the manual mode**, see page 16. **To use a preset program**, see page 19. **To create and use a Custom program**, see pages 20 and 21. **To use a Heart Rate program**, see page 22. **To use an iFIT MP3, CD, or video program**, see page 26. **To use an iFIT program directly from our Web site**, see page 28. **To operate the personal television**, see page 29.

HOW TO TURN ON THE POWER

- 1 Plug in the power cord (see page 13). Next, locate the reset/off circuit breaker on the treadmill frame near the power cord. Make sure that the circuit breaker is in the reset position.

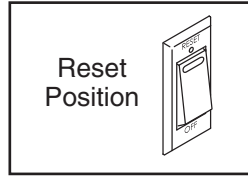

- 2 Stand on the foot rails of the treadmill. Find the clip attached to the key, and slide the clip securely onto the waistband of your clothes. Next, insert the key into the console. After a moment, the display will light, and after a few seconds, the television will turn on. **Important: In an emergency situation, the key can be pulled from the console, causing the walking belt to slow to a stop. Test the clip by carefully taking a few steps backward; if the key is not pulled from the console, adjust the position of the clip.**

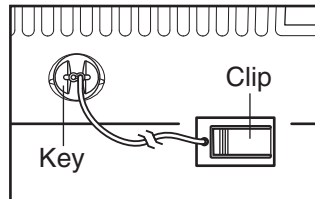

Note: To prevent damage to the walking platform, wear clean athletic shoes while using the treadmill. The first time the treadmill is used, observe the alignment of the walking belt, and center the walking belt if necessary (see page 35).

HOW TO USE THE MAIN MENU

The console's main menu allows you to view information and to enter settings before you begin exercising. Follow the steps below to use the main menu.

- 1 **Press the Menu button.**

When the Menu button is pressed, the main menu will appear in the display. The main menu includes four options: ODOMETER, SELECT USER, USER SETUP, and TREADMILL SETUP.

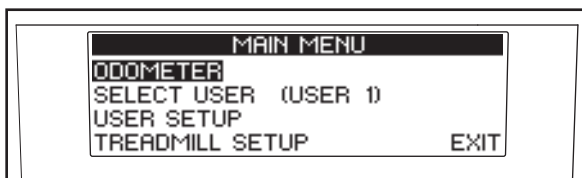

To highlight options within the main menu, press the up and down arrow buttons beside the Menu button.

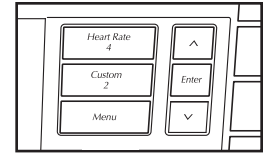

To view the odometer, see step 2. **To designate yourself as User 1 or User 2**, see step 3. **To enter user information**, see step 4. **To change console settings**, see step 5.

- 2 **View the Odometer.**

Highlight the word ODOMETER in the main menu and then press the Enter button.

When the Enter button is pressed, the display will show the total number of miles run by User 1 and User 2 since the treadmill was purchased. In addition, the display will show the trip distance—the distance run during a recent period of time, such as the most recent month—for User 1 and User 2. To reset the trip distance, first highlight USER 1 or USER 2 and press the Enter button. Then, highlight NO or YES and press the Enter button.

To reselect the main menu, highlight EXIT and then press the Enter button.

- 3 **Designate yourself as User 1 or User 2.**

The console can keep track of information and save settings for two different users. Highlight the words SELECT USER in the main menu and then press the Enter button.

To identify yourself as User 1 or User 2, highlight USER 1 or USER 2 and then press the Enter button.

The console can automatically prompt you to identify yourself as User 1 or User 2 each time you insert the key into the console. Highlight the words SELECT USER in the main menu and then press the Enter button. Next, highlight USER DISPLAY OPTIONS and press the Enter button. Next, highlight PROMPT FOR USER and press the Enter button. Then, highlight NO or YES and press the Enter button.

The console can also display a welcome message each time you insert the key into the console. Highlight SHOW USER WELCOME and press the Enter button. Then, highlight NO or YES and press the Enter button.

To reselect the main menu, press the Menu button twice.

4 Enter user information.

Highlight the words USER SETUP in the main menu and then press the Enter button.

To enter your weight, first make sure that you have identified yourself as User 1 or User 2 (see step 3 on page 15). Next, highlight ENTER WEIGHT and press the Enter button. Next, press the up and down arrow buttons to enter your weight. Then, press the Enter button.

To enter your age, first highlight ENTER AGE and press the Enter button. Next, press the up and down arrow buttons to enter your age. Then, press the Enter button.

To reselect the main menu, highlight EXIT and then press the Enter button.

5 Change console settings if desired.

Highlight the words TREADMILL SETUP in the main menu and then press the Enter button.

The console can display information such as distance and weight using either the English system or the metric system. To select the desired system, first highlight DISPLAY UNITS and press the Enter button. Then, highlight ENGLISH or METRIC and press the Enter button.

When a Walk, Jog, Run, or Custom program is selected, a graph of the speed settings of the program will appear in the display. The display can also show a graph of the incline settings of the program. Highlight INCLINE GRAPHS and press the Enter button. Then, highlight NO or YES and press the Enter button.

The console also features a “demo mode” that can be used while the treadmill is displayed in a store. While the demo mode is selected, the power cord can be plugged in, the key can be removed from the console, and the display and the television will remain on. The console buttons will not function. Highlight DEMO MODE and then press the Enter button. Next, highlight OFF (to turn off the demo mode), LOGO (to display a logo), ROAD (to display an animation of a runner on a road), or PROGRAMS (to display previews of various programs). Then, press the Enter button.

To reselect the main menu, highlight EXIT and then press the Enter button.

HOW TO USE THE MANUAL MODE

1 Insert the key into the console.

See HOW TO TURN ON THE POWER on page 15.

2 Use the main menu to enter or change settings if desired.

See HOW TO USE THE MAIN MENU on page 15.

3 Select the manual mode.

Each time the key is inserted, the manual mode will be selected. If you have selected a program, press any of the program buttons repeatedly until the words MANUAL MODE appear in the display.

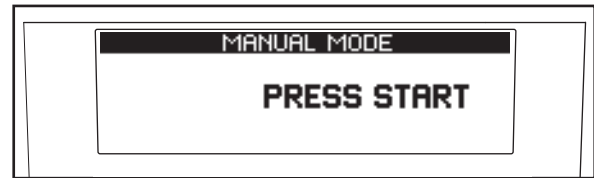

4 Start the walking belt and adjust the speed.

To start the walking belt, press the Start button, the Speed increase button, or one of the twelve buttons on the right side of the console.

If the Start button or the Speed increase button is pressed, the walking belt will begin to move at 1 mph. As you exercise, change the speed of the walking belt as desired by pressing the Speed increase and decrease buttons. Each time a button is pressed, the speed setting will change by 0.1 mph; if a button is held down, the speed setting will change in increments of 0.5 mph. If one of the twelve buttons on the right side of the console is pressed, the walking belt will gradually increase in speed until it reaches the selected speed setting.

To stop the walking belt, press the Stop button. To restart the walking belt, press the Start button, the Speed increase button, or one of the twelve buttons on the right side of the console.

5 Change the incline of the treadmill as desired.

To change the incline of the treadmill, press the Incline increase and decrease buttons or one of the twelve buttons on the left side of the console.

Each time the Incline increase or decrease button is pressed, the incline will change by 0.5%. If one of the twelve buttons on the left side of the console is pressed, the incline will gradually increase until it reaches the selected incline setting.

6 Select a display mode and monitor your progress with the display and the intensity level bar.

As you walk or run on the treadmill, the display can show the following workout information:

- The elapsed time.
- The distance that you have walked or run.
- The speed of the walking belt.
- The incline level of the treadmill.
- The approximate number of calories you have burned.
- The approximate number of grams of carbs you have burned.
- Your walking or running pace, in minutes per mile or minutes per kilometer.
- Your heart rate. Note: Your heart rate can be displayed only while you use the handgrip pulse sensor or the optional chest pulse sensor.
- In addition, the display can show a “workout history”—a graph that represents the speed settings that you select during your workout. At the beginning of each minute of your workout, an additional column will appear in the graph; as you increase or decrease the speed setting, the height of the column will increase or decrease.
- The display can also show an animation of a runner on a road. As you increase or decrease the speed setting, the runner will run at a faster or slower speed.

When the manual mode is selected, the console offers eight display modes. The display mode that you select will determine which workout information is shown. For example, the first display mode shows only the elapsed time and the distance that you have walked or run. Press the Display button repeatedly to select the desired display mode.



Note: Regardless of which display mode you select, the speed or incline setting will appear in the display for a few seconds each time you change the setting. In addition, your heart rate will appear in the display for up to 40 seconds each time you use the handgrip pulse sensor or put on the optional chest pulse sensor. Note: If you select the display mode shown below, your heart rate will be shown in place of the approximate number of grams of carbs you have burned.

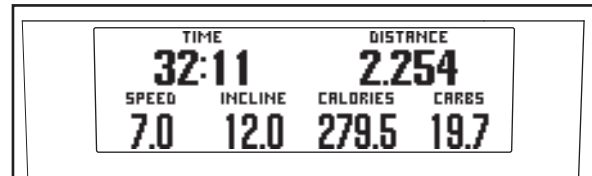

As you exercise, the intensity level bar will indicate the approximate intensity level of your exercise. For example, if half of the indicators in the bar are lit, the bar shows that your intensity level is ideal for aerobic exercise.

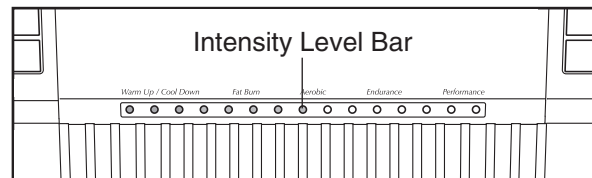

To reset the console, press the Stop button, remove the key, and then reinsert the key.

7 Measure your heart rate if desired.

Note: If you use the handgrip pulse sensor and the optional chest pulse sensor at the same time, the display will not show your heart rate accurately.

To use the handgrip pulse sensor, first remove the sheets of clear plastic from the metal contacts on the handgrip pulse sensor. Next, **stand on the foot rails** and hold the metal contacts—**avoid moving your hands**. When your pulse is detected, your heart rate will appear in the display. **For the most accurate heart rate reading, continue to hold the contacts for about 15 seconds.**

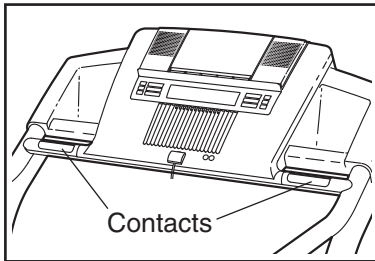

8 Turn on the fan if desired.

To turn on the fan at low speed, press the Fan button. To turn on the fan at medium speed, press

the button a second time. To turn on the fan at high speed, press the button a third time. To select the auto fan mode, press the button a fourth time. When the auto fan mode is selected, the speed of the fan will automatically increase or decrease as the speed of the walking belt increases or decreases.

To turn off the fan, press the Fan button again. Note: If the fan is on when the walking belt stops, the fan will automatically turn off after a few minutes.

9 When you are finished exercising, remove the key.

Step onto the foot rails, press the Stop button, and adjust the incline of the treadmill to the lowest setting. **The incline must be at the lowest setting when the treadmill is folded to the storage position or the treadmill will become damaged.** Next, remove the key from the console and put it in a secure place.

When you are finished using the treadmill, switch the reset/off circuit breaker to the “off” position and unplug the power cord.

HOW TO USE A PRESET PROGRAM

1 Insert the key into the console.

See HOW TO TURN ON THE POWER on page 15.

2 Use the main menu to enter or change settings if desired.

See HOW TO USE THE MAIN MENU on page 15.

3 Select a preset program.

To select a preset program, press the Walk, Jog, or Run button repeatedly.



When a preset program is selected, the display will show the name of the program, the maximum incline setting and the maximum speed setting of the program, and the program time. In addition, a graph of the speed settings of the program will appear in the center of the display. Note: A graph of the incline settings of the program may also appear (see step 5 on page 15).

Each preset program is divided into 30 one-minute segments. One speed setting and one incline setting are programmed for each segment. Note: The same speed setting and/or incline setting may be programmed for two or more consecutive segments.

4 Press the Start button to start the program.

A moment after the button is pressed, the treadmill will automatically adjust to the first speed and incline settings of the program. Hold the handrails and begin walking.

5 Select a display mode and monitor your progress with the display.

When a preset program is selected, the console offers three display modes. Press the Display button repeatedly to select the desired display mode.

If the first or second display mode is selected, a graph of the speed settings of the program will appear in the display. A small arrow below the graph will indicate your progress.

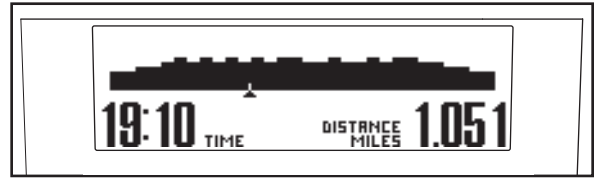

At the end of the first one-minute segment of the program, a series of tones will sound. If a different speed setting and/or incline setting is programmed for the second segment, the speed setting and/or incline setting will appear at the top of the display for a moment (or flash in the display, depending on which display mode is selected) to alert you. When the first segment ends, the treadmill will automatically adjust to the speed and incline settings for the second segment.

The program will continue in this way until the small arrow reaches the right end of the graph. The walking belt will then slow to a stop.

If the third display mode is selected, the display will show an animation of a runner.

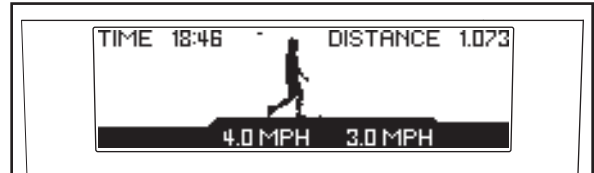

At the end of the first one-minute segment of the program, a series of tones will sound. If a different speed setting is programmed for the second segment, the speed setting will move along the bottom of the display to alert you. If a different incline setting is programmed, the incline setting will appear at the top of the display for a moment. When the first segment ends, the treadmill will automatically adjust to the speed and incline settings for the second segment.

The program will continue in this way until the last segment ends. The walking belt will then slow to a stop.

If the speed or incline setting for the current segment is too high or too low, you can override the setting by pressing the Speed or Incline buttons; however, when the next segment begins, **the treadmill will automatically adjust to the speed and incline settings for the next segment.**

To stop the program at any time, press the Stop button. To restart the program, press the Start button. The walking belt will begin to move at 1 mph. When the next segment of the program begins, the treadmill will automatically adjust to the speed and incline settings for the next segment.

6 Measure your heart rate if desired.

See step 7 on page 18.

7 Turn on the fan if desired.

See step 8 on page 18.

8 When you are finished exercising, remove the key from the console.

When the program ends, **make sure that the incline of the treadmill is at the lowest setting.** Next, remove the key from the console and put it in a safe place.

When you are finished using the treadmill, switch the reset/off circuit breaker to the “off” position and unplug the power cord.

HOW TO CREATE A CUSTOM PROGRAM

1 Insert the key into the console.

See HOW TO TURN ON THE POWER on page 15.

2 Use the main menu to enter or change settings if desired.

See HOW TO USE THE MAIN MENU on page 15.

3 Select a Custom program.

To select a Custom program, press the Custom button once or twice.

If the Custom program has not yet been defined, the display will show a program time of three minutes. If the program time is more than three minutes, see HOW TO USE A CUSTOM PROGRAM on page 21.

Each Custom program is divided into one-minute segments. One speed setting and one incline setting can be programmed for each segment.

4 Press the Start button to start the program.

A moment after the button is pressed, the walking belt will begin to move. Hold the handrails and begin walking.

5 Select a display mode and program the desired speed and incline settings.

When a Custom program is selected, the console offers three display modes. Press the Display button repeatedly to select the desired display mode.

To program a speed setting and an incline setting for the first one-minute segment of the program, simply adjust the speed and incline of the treadmill as desired by pressing the Speed and Incline buttons.

When the first segment ends, a series of tones will sound and the current speed setting and the current incline setting will be saved in memory.

Program a speed setting and an incline setting for the second segment as described above. Continue programming speed and incline settings for up to 30 segments.

When you are finished with your workout, press the Stop button twice. The Custom program will then be saved in memory.

6 When you are finished exercising, remove the key from the console.

See step 8 on this page.

HOW TO USE A CUSTOM PROGRAM

1 Insert the key into the console.

See HOW TO TURN ON THE POWER on page 15.

2 Use the main menu to enter or change settings if desired.

See HOW TO USE THE MAIN MENU on page 15.

3 Select a Custom program.

To select a Custom program, press the Custom button once or twice.

When a Custom program is selected, the display will show the name of the program, the maximum incline setting and the maximum speed setting of the program, and the program time. In addition, a graph of the speed settings of the program will appear in the center of the display. Note: A graph of the incline settings of the program may also appear (see step 5 on page 15).

Note: If the display shows a program time of three minutes, see HOW TO CREATE A CUSTOM PROGRAM on page 20.

Each Custom program is divided into one-minute segments. One speed setting and one incline setting are programmed for each segment.

4 Press the Start button to start the program.

A moment after the button is pressed, the treadmill will automatically adjust to the first speed and incline settings that you programmed previously. Hold the handrails and begin walking.

5 Select a display mode and monitor your progress with the display.

The Custom program will function in the same way as a preset program (see step 5 on page 19).

If desired, you can redefine to the program while using it. **To change the speed or incline setting for the current segment**, simply press the Speed or Incline buttons. When the current segment ends, the new setting will be saved in memory. **To increase the length of the program**, first wait until the program ends. Then, press the Start button and program speed and incline settings for as many additional segments as desired; Custom programs can have up to 30 segments. When you have added as many segments as desired, press the Stop button twice. **To decrease the length of the program**, press the Stop button twice at any time before the program ends.

6 Measure your heart rate if desired.

See step 7 on page 18.

7 Turn on the fan if desired.

See step 8 on page 18.

8 When you are finished exercising, remove the key from the console.

See step 8 on page 20.

HOW TO USE A HEART RATE PROGRAM

CAUTION: If you have heart problems, or if you are over 60 years of age and have been inactive, do not use the heart rate programs. If you are taking medication regularly, consult your physician to find whether the medication will affect your exercise heart rate.

Follow the steps below to use a heart rate program.

1 Put on the optional chest pulse sensor.

Note: You must wear the optional chest pulse sensor to use a heart rate program.

2 Insert the key into the console.

See HOW TO TURN ON THE POWER on page 15.

3 Use the main menu to enter or change settings if desired.

See HOW TO USE THE MAIN MENU on page 15.

4 Select a Heart Rate program.

To select a Heart Rate program, press the Heart Rate button repeatedly.

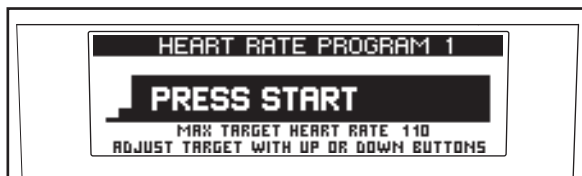

When a Heart Rate program is selected, the display will show the name of the program and the maximum target heart rate setting of the program. In addition, a graph of the target heart rate settings of the program will appear in the center of the display.

Heart Rate program 1 is divided into one-minute segments. The same target heart rate setting is programmed for all segments (except for the first two segments). Heart Rate programs 2, 3, and 4 are divided into 30 one-minute segments. One target heart rate setting is programmed for each seg-

ment. Note: The same target heart rate setting may be programmed for two or more consecutive segments.

5 Adjust the maximum target heart rate setting if desired.

To adjust the maximum target heart rate setting, press the increase and decrease buttons beside the Heart Rate button. To adjust the target heart rate setting quickly, hold down one of the buttons.

6 Press the Start button to start the program.

A moment after the button is pressed, the walking belt will begin to move. Hold the handrails and begin walking.

7 Select a display mode and monitor your progress with the display.

When a Heart Rate program is selected, the console offers two display modes. Press the Display button to select the desired display mode.

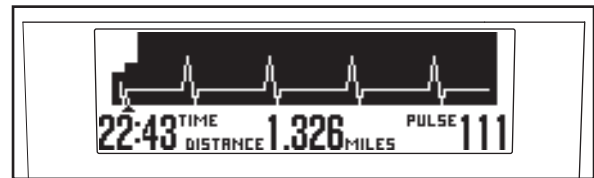

Regardless of which display mode you select, a graph of the target heart rate settings of the program will appear in the display. A white line representing your heartbeat will also appear; each time a heartbeat is detected, an additional peak will appear in the line. A small arrow below the graph will indicate your progress.

During each one-minute segment of the program, the console will compare your heart rate to the current target heart rate setting. If your heart rate is too far below or above the target heart rate setting, the speed of the walking belt or the incline of the treadmill will automatically change to bring your heart rate closer to the target heart rate setting. Each time the speed or incline changes, the speed setting and the incline setting will appear at the top of the display for a moment (or flash in the display, depending on which display mode is selected) to alert you.

When each segment ends, a series of tones will sound.

If the speed or incline setting for the current segment is too high or too low, you can override the setting by pressing the Speed or Incline buttons; however, when the console compares your heart rate to the current target heart rate setting, the speed or incline of the treadmill may automatically change.

To stop the program at any time, press the Stop button. To restart the program, press the Start button. The walking belt will begin to move at 1 mph. When the console compares your heart rate to the current target heart rate setting, the speed or incline of the treadmill may automatically change.

If Heart Rate program 1 is selected, the program will continue until you stop it by pressing the Stop

button. If Heart Rate program 2, 3, or 4 is selected, the program will continue until the small arrow reaches the right end of the graph. The walking belt will then slow to a stop.

8 Turn on the fan if desired.

See step 8 on page 18.

9 When you are finished exercising, remove the key from the console.

See step 8 on page 20.

HOW TO CONNECT THE TREADMILL TO USE iFIT PROGRAMS

To use iFIT MP3 or CD programs, the treadmill must be connected to your MP3 player, CD player, portable stereo, home stereo, or computer. See pages 24 and 25 for connecting instructions. **To use iFIT programs directly from our Web site**, the treadmill must be connected to your computer. See page 25 for connecting instructions. **To use iFIT video programs**, the treadmill must be connected to your VCR. See page 26 for connecting instructions.

HOW TO CONNECT YOUR MP3 PLAYER OR CD PLAYER

- A. Plug one end of the included 3.5 mm to 3.5 mm stereo audio cable into the input jack on the console. Plug the other end of the cable into a jack on your MP3 player or CD player. Plug your headphones into the headphone jack on the console.

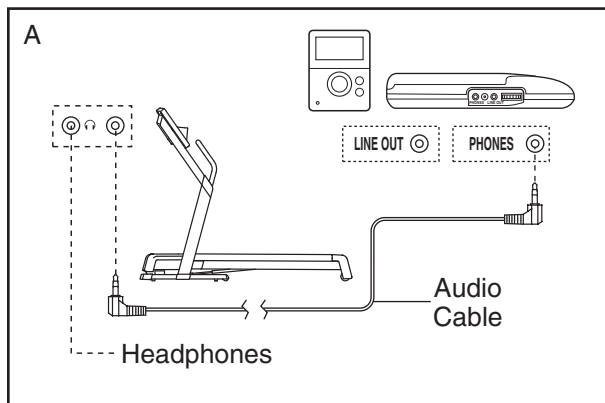

HOW TO CONNECT YOUR PORTABLE STEREO

Note: If your stereo has an RCA-type AUDIO OUT jack, see instruction A below. If your stereo has a 3.5 mm LINE OUT jack, see instruction B. If your stereo has only a PHONES jack, see instruction C.

- A. Plug one end of a long 3.5 mm to RCA stereo audio cable (available at electronics stores) into the input jack on the console. Plug the other end of the cable into the AUDIO OUT jack on your stereo.

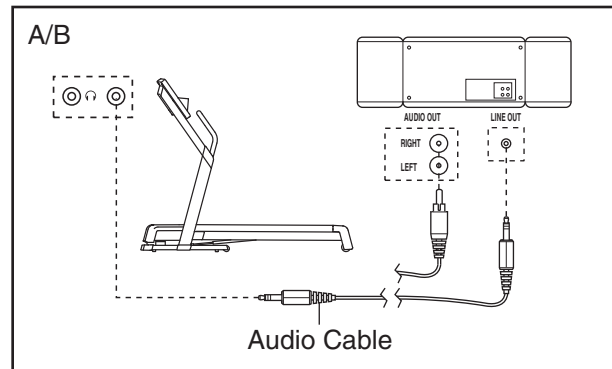

- B. See the drawing above. Plug one end of a long 3.5 mm to 3.5 mm stereo audio cable (available at electronics stores) into the input jack on the console. Plug the other end of the cable into the LINE OUT jack on your stereo. Note: While the cable is plugged into the LINE OUT jack, do not plug your headphones into the headphone jack on the console.

- C. Plug one end of a long 3.5 mm to 3.5 mm stereo audio cable (available at electronics stores) into the input jack on the console. Plug the other end of the cable into the PHONES jack on your stereo. Plug your headphones into the headphone jack on the console.

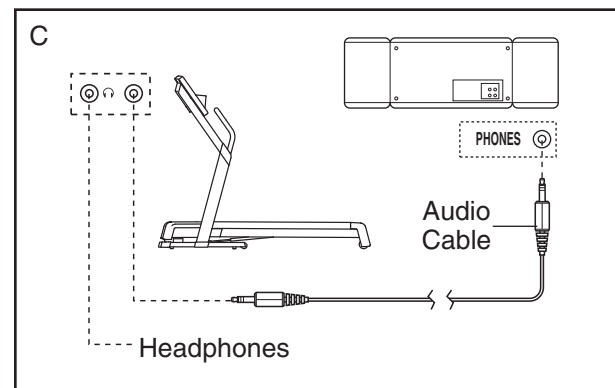

HOW TO CONNECT YOUR HOME STEREO

Note: If your stereo has an unused LINE OUT jack, see instruction A below. If the LINE OUT jack is being used, see instruction B.

- A. Plug one end of a long 3.5 mm to RCA stereo audio cable (available at electronics stores) into the input jack on the console. Plug the other end of the cable into the LINE OUT jack on your stereo. Note: While the cable is plugged into the LINE OUT jack, do not plug your headphones into the headphone jack on the console.

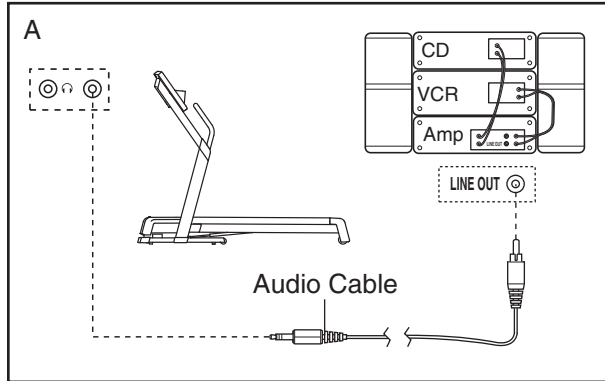

- B. Plug one end of a long 3.5 mm to RCA stereo audio cable (available at electronics stores) into the input jack on the console. Plug the other end of the cable into an RCA Y-adapter (available at electronics stores). Next, remove the wire that is currently plugged into the LINE OUT jack on your stereo and plug the wire into the unused side of the Y-adapter. Plug the Y-adapter into the LINE OUT jack on your stereo. Note: While the Y-adapter is plugged into the LINE OUT jack, do not plug your headphones into the headphone jack on the console.

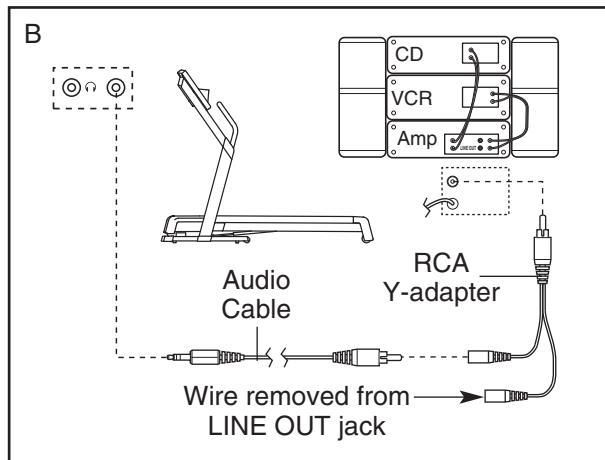

HOW TO CONNECT YOUR COMPUTER

- A. Plug one end of a long 3.5 mm to 3.5 mm stereo audio cable (available at electronics stores) into the input jack on the console. Plug the other end of the cable into the LINE OUT jack on your computer. Note: While the cable is plugged into the LINE OUT jack, do not plug your headphones into the headphone jack on the console.

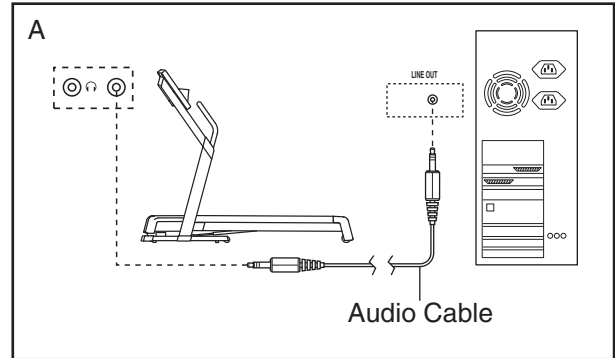

HOW TO CONNECT YOUR VCR

Note: If your VCR has an unused AUDIO OUT jack, see instruction A below. If the AUDIO OUT jack is being used, see instruction B. If you have a TV with a built-in VCR, see instruction B. If your VCR is connected to your home stereo, see **HOW TO CONNECT YOUR HOME STEREO** on page 25.

- A. Plug one end of a long 3.5 mm to RCA stereo audio cable into the input jack on the console. Plug the other end of the cable into the AUDIO OUT jack on your VCR.

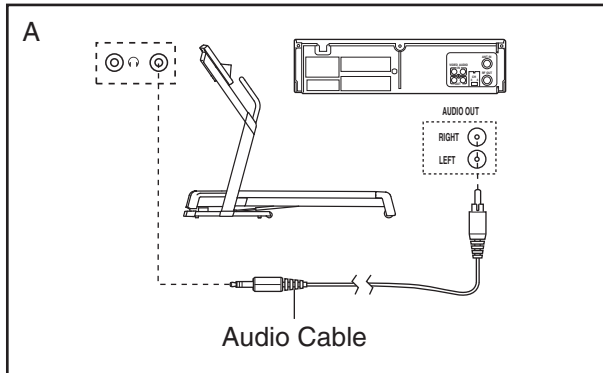

- B. Plug one end of a long 3.5 mm to RCA stereo audio cable into the input jack on the console. Plug the other end of the cable into an RCA Y-adapter (available at electronics stores). Next, remove the wire that is currently plugged into the AUDIO OUT jack on your VCR and plug the wire into the unused side of the Y-adapter. Plug the Y-adapter into the AUDIO OUT jack on your VCR.

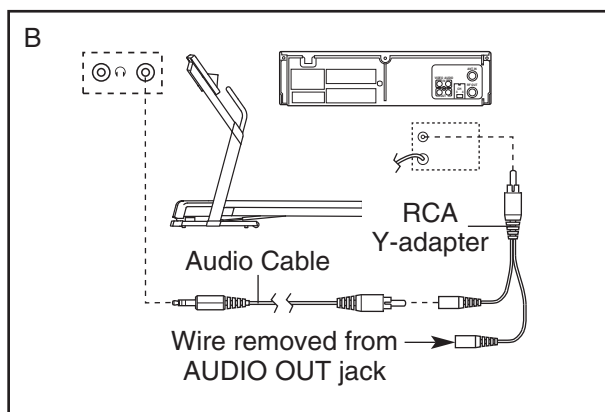

HOW TO USE AN iFIT MP3, CD, OR VIDEO PROGRAM

To use an iFIT MP3, CD, or video program, the treadmill must be connected to your MP3 player, CD player, or VCR. See **HOW TO CONNECT THE TREADMILL TO USE iFIT PROGRAMS** on pages 24 to 26. **To purchase and download iFIT MP3 programs, go to www.iFIT.com. To purchase iFIT CDs or videocassettes, call the toll-free telephone number on the front cover of this manual.**

Follow the steps below to use an iFIT MP3, CD, or video program.

- 1 Insert the key into the console.**
See **HOW TO TURN ON THE POWER** on page 15.
- 2 Use the main menu to enter or change settings if desired.**

See **HOW TO USE THE MAIN MENU** on page 15.

- 3 Select the iFIT mode.**

To select the iFIT mode, press the iFIT button.

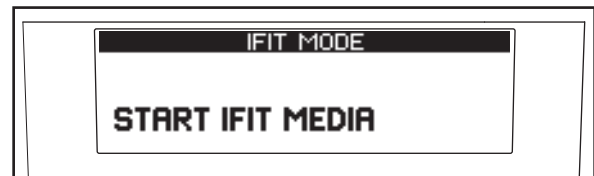

When the iFIT mode is selected, the words IFIT MODE will appear in the display. Note: If the television is on, it will automatically turn off so the iFIT program can be heard through the console's speakers.

- 4 Press the Play button on your MP3 player, CD player, or VCR.**

Note: If you are using an iFIT CD, insert the CD into your CD player; if you are using an iFIT videocassette, insert the videocassette into your VCR.

A moment after the Play button is pressed, your personal trainer will begin guiding you through your workout. Simply follow your personal trainer's instructions.

5 Select a display mode and monitor your progress with the display and the intensity level bar.

When the iFIT mode is selected, the console offers eight display modes (see step 6 on page 17). Press the Display button repeatedly to select the desired display mode.

During the program, an electronic “chirping” sound will alert you when the speed and/or incline of the treadmill is about to change. **CAUTION: Always listen for the “chirp” and be prepared for speed and/or incline changes. In some instances, the speed and/or incline may change before your personal trainer describes the change.**

If the speed or incline settings are too high or too low, you can manually override the settings at any time by pressing the Speed or Incline buttons on the console. However, **when the next “chirp” is heard, the speed and/or incline will change to the next settings of the program.**

To stop the walking belt at any time, press the Stop button on the console. To restart the walking belt, press the Start button. After a moment, the walking belt will begin to move at 1 mph. **When the next “chirp” is heard, the speed and/or incline will change to the next settings of the program.**

When the program ends, the walking belt will slow to a stop. Note: To use another MP3, CD, or video program, press the Stop button or remove the key and go to step 1 on page 26.

Note: If the speed and/or incline of the treadmill does not change when a “chirp” is heard:

- Make sure that the iFIT logo appears in the display and that the display is not paused. If the display is paused, press the Start button on the console.
- Adjust the volume of your MP3 player, CD player, or VCR. If the volume is too high or too low, the console may not detect the program signals.
- Make sure that the audio cable is properly connected.
- If you are using a portable CD player and the CD skips, set the CD player on the floor or another flat surface instead of on the console.

6 Measure your heart rate if desired.

See step 7 on page 18.

7 Turn on the fan if desired.

See step 8 on page 18.

8 When you are finished exercising, remove the key from the console.

See step 8 on page 20.

CAUTION: Always remove iFIT CDs and video-cassettes from your CD player and VCR and disconnect your MP3 player when you are not using them.

HOW TO USE AN iFIT PROGRAM DIRECTLY FROM OUR WEB SITE

Our Web site at www.iFIT.com allows you to access programs directly from the internet.

To use a program from our Web site, the treadmill must be connected to your home computer. See **HOW TO CONNECT YOUR COMPUTER** on page 25. In addition, you must have an internet connection and an internet service provider. A list of specific system requirements is found on our Web site.

Follow the steps below to use a program from our Web site.

1 Insert the key into the console.

See **HOW TO TURN ON THE POWER** on page 15.

2 Use the main menu to enter or change settings if desired.

See **HOW TO USE THE MAIN MENU** on page 15.

3 Select the iFIT mode.

See step 3 on page 26.

4 Go to your computer and start an internet connection.

5 Start your web browser, if necessary, and go to our Web site at www.iFIT.com.

6 Follow the desired links on our Web site to select a program.

Read and follow the on-line instructions for using a program.

7 Follow the on-line instructions to start the program.

When you start the program, an on-screen countdown will begin.

8 Return to the treadmill and stand on the foot rails. Find the clip attached to the key and slide the clip onto the waistband of your clothes.

9 Select a display mode and monitor your progress with the display and the intensity level bar.

When the iFIT mode is selected, the console offers eight display modes (see step 6 on page 17). Press the Display button repeatedly to select the desired display mode.

When the on-screen countdown ends, the program will begin and the walking belt will begin to move. Hold the handrails and begin walking. During the program, an electronic “chirping” sound will alert you when the speed and/or incline of the treadmill is about to change. **CAUTION: Always listen for the “chirp” and be prepared for speed and/or incline changes.**

If the speed or incline settings are too high or too low, you can manually override the settings at any time by pressing the Speed or Incline buttons on the console. However, **when the next “chirp” is heard, the speed and/or incline will change to the next settings of the program.**

To stop the walking belt at any time, press the Stop button on the console. To restart the walking belt, press the Start button. After a moment, the walking belt will begin to move at 1 mph. **When the next “chirp” is heard, the speed and/or incline will change to the next settings of the program.**

When the program ends, the walking belt will slow to a stop. Note: To use another program, press the Stop button and go to step 5.

Note: If the speed and/or incline of the treadmill does not change when a “chirp” is heard, make sure that the iFIT logo appears in the display and that the display is not paused. In addition, make sure that the audio cable is properly connected.

10 Measure your heart rate if desired.

See step 7 on page 18.

11 Turn on the fan if desired.

See step 8 on page 18.

12 When you are finished exercising, remove the key from the console.

See step 8 on page 20.

HOW TO OPERATE THE PERSONAL TELEVISION

IMPORTANT: Before operating the television, you must connect an antenna, a 75 ohm CATV cable, or a VCR to the 75 ohm antenna terminal on the treadmill. See page 11 for instructions.

Follow the steps below to operate the television.

1 Insert the key into the console.

See HOW TO TURN ON THE POWER on page 15.

2 Press the Power button to turn on the television.

When the key is inserted, the television will automatically turn on. If you have turned off the television, turn it on by pressing the Power button.

Note: When the iFIT mode is selected, the television will automatically turn off so the audio of the iFIT.com program can be heard through the console's speakers. To use an iFIT video program, **connect your VCR as described on page 26 and view the video of the iFIT program on an external television.**

3 Press the Channel buttons to select the desired channel.

When the television is turned on, the screen will show the last channel that was selected. To select

a different channel, press the Channel buttons. The selected channel number will appear on the screen for a few seconds. Note: The television is equipped with a channel memorizing function that allows you to go directly from the current channel to the next channel saved in memory. Before channels can be selected in this way, they must be saved in the television's memory. See HOW TO USE THE INFORMATION MODE on page 30.

4 Press the Volume buttons to adjust the volume.

When either Volume button is pressed, the volume level indicator will appear on the screen for a few seconds. Note: When the iFIT mode is selected, the Volume buttons will control the volume of the audio of the iFIT program.

To use earphones or headphones (not included), plug them into the headphone jack on the console.

5 When you are finished using the television, press the Power button.

Press the Power button to turn off the television. Note: Removing the key from the console will also turn off the television.

HOW TO USE THE INFORMATION MODE

The console features an information mode that allows you to view treadmill usage information, select a system of measurement for the console, and turn on and turn off the demo mode. The information mode also allows you to adjust the settings of the television and to save channels into the television's memory.

Follow the steps below to use the information mode.

1 Hold down the Stop button while inserting the key into the console.

When the information mode is selected, the display will show the total number of hours that the treadmill has been used and the total number of miles or kilometers that the walking belt has moved.

In addition, the display will show the word ENGLISH or METRIC to indicate which system of measurement is selected. To change the system of measurement, press the Speed increase button.

The display will also show the words DEMO MODE and the current setting: OFF, LOGO, ROAD, or PROGRAMS (see step 5 on page 16). To change the setting, press the Speed decrease button repeatedly.

2 Press the Power button and adjust the brightness, contrast, color, sharpness, and/or hue of the television.

When the Power button is pressed, the brightness level indicator will appear on the television screen. Press the Volume buttons to adjust the brightness setting if desired.

Next, press the Channel buttons until the contrast, color, sharpness, or hue level indicator appears. Adjust the settings, if desired, by pressing the Volume buttons.

3 Press the Power button again and add or delete channels.

After all valid channels available in your area have been saved into the television's memory (see step

5 on this page), you can manually add channels or delete unwanted channels.

To add or delete a channel, first press the Channel buttons until the desired channel number appears on the screen. Then, press the Volume increase button to add the channel, or the Volume decrease button to delete the channel. Continue this process until you have added all desired channels and deleted all unwanted channels.

4 Press the Power button again and select an antenna connection or a cable connection.

After the Power button is pressed, press the Volume decrease button to select the Air setting, the Volume increase button to select the Standard Cable setting, the Channel decrease button to select the Cable IRC setting, or the Channel increase button to select the Cable HRC setting. Note: The setting that you select will **not** appear on the screen. If you have connected an antenna to the treadmill, the Air setting should be selected. If you have connected a CATV cable, one of the three Cable settings should be selected; try all three Cable settings, if necessary, to find the optimal setting.

5 Press the Power button again and save channels into the television's memory.

When the Power button is pressed, the television will begin scanning all of the channels available in your area. When no broadcast signal is detected on a channel, the channel will be skipped. When a broadcast signal is detected, the channel will be saved into memory and the next channel will be selected. This process will continue until the highest channel is reached. **Do not remove the key while the television is scanning channels.**

6 When you are finished using the information mode, remove the key.

To exit the information mode at any time (except while the television is scanning channels), remove the key from the console.

HOW TO ADJUST THE CUSHIONING SYSTEM

The treadmill features a cushioning system that reduces the impact as you walk or run on the treadmill. To increase the firmness of the walking platform, step off the treadmill and slide the cushion adjusters toward the front of the treadmill. To decrease the firmness, slide the cushion adjusters toward the back of the treadmill. **Note: It may be helpful to lift on the walking platform as you slide the adjusters. Make sure that both adjusters are set at the same firmness level. The faster you run on the treadmill, or the more you weigh, the firmer the walking platform should be.**

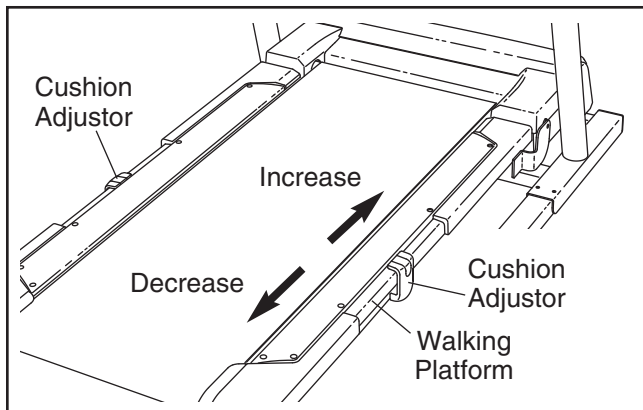

THE OPTIONAL CHEST PULSE SENSOR

An optional chest pulse sensor adds even more features to the console. The chest pulse sensor offers hands-free operation, and enables you to use the two heart rate programs. **To purchase the optional chest pulse sensor, call the toll-free telephone number on the front cover of this manual.**

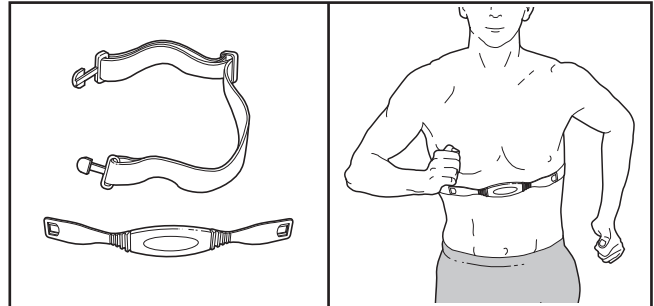

HOW TO FOLD AND MOVE THE TREADMILL

HOW TO FOLD THE TREADMILL FOR STORAGE

Before folding the treadmill, adjust the incline to the lowest position. If this is not done, the treadmill may become permanently damaged. Remove the key and unplug the power cord. **CAUTION:** You must be able to safely lift 45 pounds (20 kg) to raise, lower, or move the treadmill.

1. Hold the metal frame firmly in the location shown by the arrow at the right. **CAUTION:** To decrease the possibility of injury, do not lift the frame by the plastic foot rails. Make sure to bend your legs and keep your back straight. As you raise the frame, make sure to lift with your legs rather than your back. Raise the frame about halfway to the vertical position.

2. Move your right hand to the position shown and hold the treadmill firmly. Using your left hand, pull the latch knob to the left and hold it. Raise the treadmill until the pin on the latch knob is between the frame and the foot rail. Then, carefully release the latch knob. **Make sure that the frame is held securely by the pin.**

To protect the floor or carpet from damage, place a mat under the treadmill. Keep the treadmill out of direct sunlight. Do not leave the treadmill in the storage position in temperatures above 85° Fahrenheit.

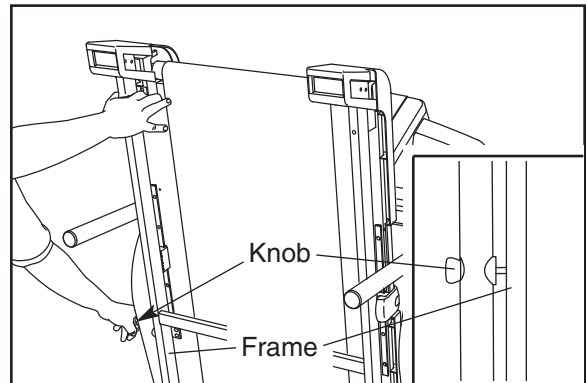
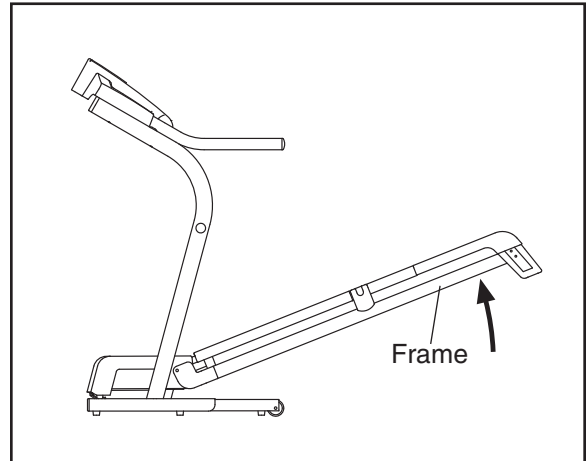

HOW TO MOVE THE TREADMILL

Before moving the treadmill, convert the treadmill to the storage position as described above. **Make sure that the frame is held securely by the pin on the latch knob.**

1. Hold the handrails and place one foot against one of the wheels.
2. Tilt the treadmill back until it rolls freely on the wheels. Carefully move the treadmill to the desired location. **Never move the treadmill without tipping it back. To reduce the risk of injury, use extreme caution while moving the treadmill. Do not attempt to move the treadmill over an uneven surface.**
3. Place one foot against one of the wheels, and carefully lower the treadmill until it is resting in the storage position.

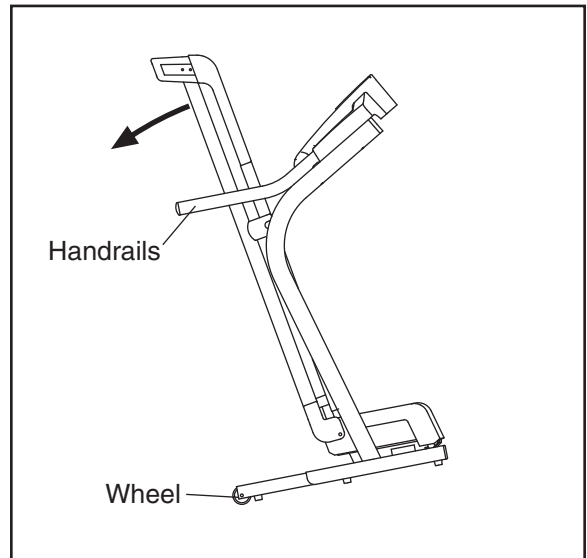

HOW TO LOWER THE TREADMILL FOR USE

1. Hold the upper end of the treadmill with your right hand as shown. Using your left hand, pull the latch knob to the left and hold it. Pivot the treadmill down until the frame is past the pin on the latch knob.

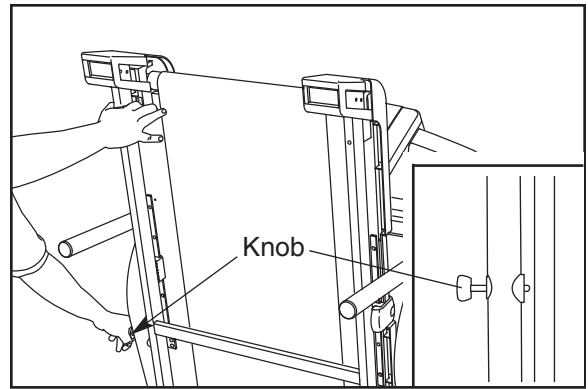

2. **Hold the metal frame firmly with both hands**, and lower the frame to the floor. **CAUTION: To decrease the possibility of injury, do not lower the frame by gripping only the plastic foot rails. Do not drop the frame to the floor. Make sure to bend your legs and keep your back straight.**

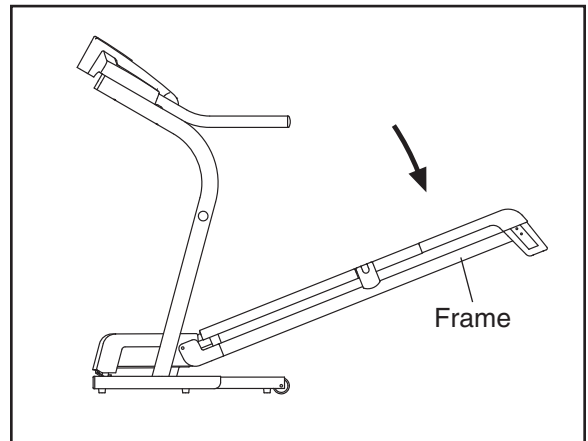

TROUBLESHOOTING

Most treadmill problems can be solved by following the steps below. Find the symptom that applies, and follow the steps listed. If further assistance is needed, see the front cover of this manual.

PROBLEM: The power does not turn on

SOLUTION: a. Make sure that the power cord is plugged into a surge suppressor, and that the surge suppressor is plugged into a properly grounded outlet (see page 13). Use only a single-outlet surge suppressor that meets all of the specifications described on page 13. Important: The treadmill is not compatible with GFCI-equipped outlets.

b. After the power cord has been plugged in, make sure that the key is inserted into the console.

c. Check the reset/off circuit breaker located on the treadmill frame near the power cord. If the switch protrudes as shown, the circuit breaker has tripped. To reset the circuit breaker, wait for five minutes and then press the switch to the reset position.

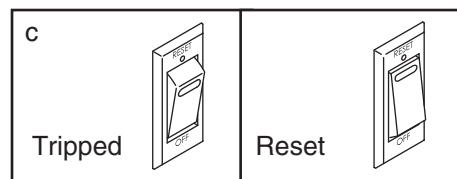

PROBLEM: The power turns off during use

SOLUTION: a. Check the reset/off circuit breaker (see the drawing above). If the circuit breaker has tripped, wait for five minutes and then press the switch to the reset position.

b. Make sure that the power cord is plugged in. If the power cord is plugged in, unplug it, wait for five minutes, and then plug it back in.

c. Remove the key from the console. Reinsert the key into the console.

d. If the treadmill still will not run, see the front cover of this manual.

PROBLEM: The displays of the console do not function properly

SOLUTION: a. Remove the key from the console and **UNPLUG THE POWER CORD**. Next, carefully lower the Uprights (85). Remove the two indicated 3/4" Screws (7). Note: A phillips screwdriver with a shaft at least 8" long is needed.

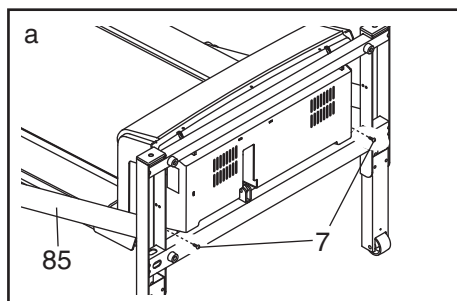

Raise the Uprights (85) to the vertical position. Remove the three 3/4" Screws (7) from the Hood (33), and carefully pivot the Hood off.

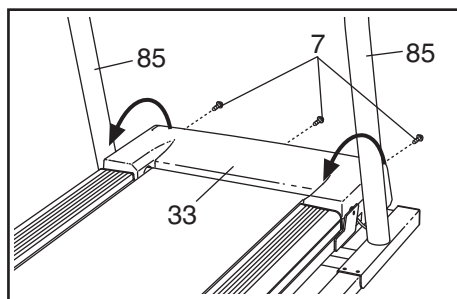

Locate the Reed Switch (22) and the Magnet (18) on the left side of the Pulley (17). Turn the Pulley until the Magnet is aligned with the Reed Switch. **Make sure that the gap between the Magnet and the Reed Switch is about 1/8"**. If necessary, move the Reed Switch slightly using a slotted screwdriver. Next, reattach the Motor Hood (not shown), making sure that the 3/4" Screws (not shown) are in the same holes from which they were removed. Then, run the treadmill for a few minutes to check for a correct speed reading.

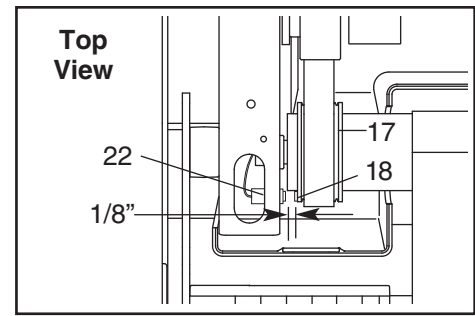

PROBLEM: The walking belt slows when walked on

SOLUTION: a. Use only a single-outlet surge suppressor that meets all of the specifications described on page 13.

b. If the walking belt is overtightened, treadmill performance may decrease and the walking belt may become damaged. Remove the key and **UNPLUG THE POWER CORD**. Using the allen wrench, turn both rear roller bolts counterclockwise, 1/4 of a turn. When the walking belt is properly tightened, you should be able to lift each edge of the walking belt 3 to 4 inches off the walking platform. Be careful to keep the walking belt centered. Then, plug in the power cord, insert the key, and run the treadmill for a few minutes. Repeat until the walking belt is properly tightened.

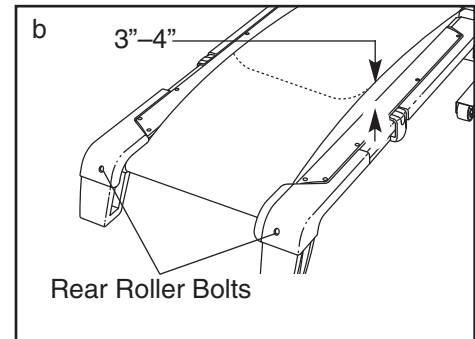

c. If the walking belt still slows when walked on, see the front cover of this manual.

PROBLEM: The walking belt is off-center or slips when walked on

SOLUTION: a. If the walking belt is off-center, remove the key and **UNPLUG THE POWER CORD**. **If the walking belt has shifted to the left**, use the allen wrench to turn the left rear roller bolt clockwise 1/2 of a turn; **if the walking belt has shifted to the right**, turn the left rear roller bolt counterclockwise 1/2 of a turn. Be careful not to overtighten the walking belt. Plug in the power cord, insert the key, and run the treadmill for a few minutes. Repeat until the walking belt is centered.

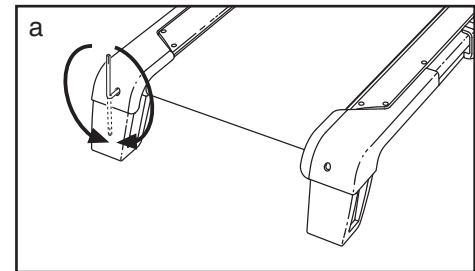

b. If the walking belt slips when walked on, first remove the key and **UNPLUG THE POWER CORD**. Using the allen wrench, turn both rear roller bolts clockwise, 1/4 of a turn. When the walking belt is correctly tightened, you should be able to lift each edge of the walking belt 3 to 4 inches off the walking platform. Be careful to keep the walking belt centered. Then, plug in the power cord, insert the key, and carefully walk on the treadmill for a few minutes. Repeat until the walking belt is properly tightened.

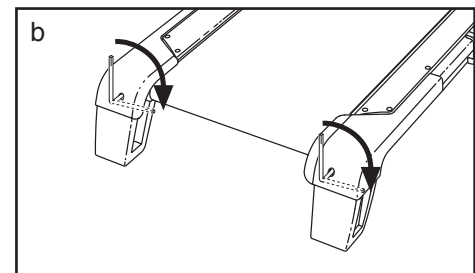

PROBLEM: The incline of the treadmill does not change correctly

SOLUTION: a. With the key in the console, press one of the Incline buttons. **While the incline is changing, remove the key.** After a few seconds, re-insert the key. The treadmill will automatically rise to the maximum incline level and then return to the minimum level. This will recalibrate the incline system.

PROBLEM: Television reception is poor

SOLUTION: a. For the television to operate properly, good reception is necessary. If you are using an antenna, make sure that it is properly connected and adjusted for optimal reception. (See HOW TO CONNECT AN ANTENNA on page 11.)

b. Check for the problems listed below and follow the applicable instructions.

- Ignition (black spots or horizontal streaks that appear on a picture that flutters or drifts)—Usually this is caused by interference from automobile ignition systems, neon lamps, electric drifts, or other electric appliances. Try changing the position of the treadmill or other electric appliances to correct the problem.
- Ghosts—Ghosts are caused by the television signal following two paths—one is the direct path and the other is reflected from tall buildings, hills, or other objects. Change the direction or position of the antenna to improve reception.
- Blue Screen—If the treadmill is located in the fringe area of a television station where the signal is weak, the picture may be of poor quality or a blue screen may appear. If the signal is weak, it may be necessary to install an external antenna to improve the picture.

Note: If one of these symptoms appears when the cable from a CATV company is connected, the symptom may be caused by the local company broadcast.

CONDITIONING GUIDELINES

⚠️ WARNING: Before beginning this or any exercise program, consult your physician. This is especially important for individuals over the age of 35 or individuals with pre-existing health problems.

The pulse sensor is not a medical device. Various factors, including your movement, may affect the accuracy of heart rate readings. The sensor is intended only as an exercise aid in determining heart rate trends in general.

The following guidelines will help you to plan your exercise program. For more detailed exercise information, obtain a reputable book or consult your physician.

EXERCISE INTENSITY

Whether your goal is to burn fat or to strengthen your cardiovascular system, the key to achieving the desired results is to exercise with the proper intensity. The proper intensity level can be found by using your heart rate as a guide. The chart below shows recommended heart rates for fat burning and aerobic exercise.

HEART RATE TRAINING ZONES							
AEROBIC	165	155	145	140	130	125	115
MAX FAT BURN	145	138	130	125	118	110	103
FAT BURN	125	120	115	110	105	95	90
Age	20	30	40	50	60	70	80

To find the proper heart rate for you, first find your age near the bottom of the chart (ages are rounded off to the nearest ten years). Next, find the three numbers above your age. The three numbers define your “training zone.” The lower two numbers are recommended heart rates for fat burning; the higher number is the recommended heart rate for aerobic exercise.

Fat Burning

To burn fat effectively, you must exercise at a relatively low intensity level for a sustained period of time. During the first few minutes of exercise, your body uses easily accessible *carbohydrate calories* for energy. Only after the first few minutes does your body begin to use stored *fat calories* for energy. If your goal

is to burn fat, adjust the speed and incline of the treadmill until your heart rate is near the lowest number in your training zone.

For maximum fat burning, adjust the speed and incline of the treadmill until your heart rate is near the middle number in your training zone.

Aerobic Exercise

If your goal is to strengthen your cardiovascular system, your exercise must be “aerobic.” Aerobic exercise is activity that requires large amounts of oxygen for prolonged periods of time. This increases the demand on the heart to pump blood to the muscles, and on the lungs to oxygenate the blood. For aerobic exercise, adjust the speed and incline of the treadmill until your heart rate is near the highest number in your training zone.

WORKOUT GUIDELINES

Each workout should include the following three parts:

A Warm-up—Start each workout with 5 to 10 minutes of stretching and light exercise. A proper warm-up increases your body temperature, heart rate and circulation in preparation for exercise.

Training Zone Exercise—After warming up, increase the intensity of your exercise until your pulse is in your training zone for 20 to 60 minutes. (During the first few weeks of your exercise program, do not keep your pulse in your training zone for longer than 20 minutes.) Breathe regularly and deeply as you exercise—never hold your breath.

A Cool-down—Finish each workout with 5 to 10 minutes of stretching to cool down. This will increase the flexibility of your muscles and will help prevent post-exercise problems.

EXERCISE FREQUENCY

To maintain or improve your condition, complete three workouts each week, with at least one day of rest between workouts. After a few months, you may complete up to five workouts each week if desired. The key to success is to make exercise a regular and enjoyable part of your everyday life.

PART LIST—Model No. NTL14905.3

R0306A

To locate the parts listed below, see the EXPLODED DRAWING attached in the center of this manual.

Key No.	Qty.	Description	Key No.	Qty.	Description
1	1	Left Foot Rail	52	1	Plastic Tie
2	10	Foot Rail Screw	53	1	Front Roller Bushing
3	2	Cushion Adjustor	54	1	Right Foot Rail
4	2	Adjustor Guide	55	1	Frame
5	2	Rear Platform Screw	56	1	Roller Ground Wire
6	1	Latch Warning Decal	57	2	Platform Nut
7	16	3/4" Screw	58	1	Idler Washer
8	10	Adjustor Guide Screw	59	1	Idler Pulley
9	1	Latch Catch	60	2	Rear Roller Star Washer
10	2	Isolator	61	1	Ground Wire
11	2	Front Platform Screw	62	2	Rear Roller Bolt
12	2	Belt Guide	63	1	Hood Foam, Right
13	4	Belt Guide Screw	64	1	Rear Roller
14	2	Frame Pivot Bolt	65	1	Filter Wire
15	1	Walking Platform	66	1	Idler Pulley Bolt
16	1	Walking Belt	67	8	Star Washer
17	1	Front Roller	68	1	Idler Arm Bolt
18	1	Magnet	69	1	Idler Arm Spacer
19	2	Frame Spacer	70	1	Handrail
20	5	Nut	71	2	Round Upright Endcap
21	1	Reed Switch Clip	72	4	Console Bolt
22	1	Reed Switch	73	1	Upright Wire Harness
23	10	1/2" Screw	74	1	Idler Arm
24	2	Hood Cover Foam	75	1	Idler Arm Spring
25	1	Drive Motor	76	1	Latch Assembly
26	1	Motor Belt	77	1	Latch Insert
27	4	Rear Foot Bolt	78	2	Handrail Endcap
28	1	Right Rear Foot	79	2	Square Upright Endcap
29	1	Left Rear Foot	80	2	Lift Frame Pivot Bolt
30	3	Cable Tie	81	6	Base Pad
31	2	Motor Bolt	82	6	1" Tek Screw
32	2	Console Screw	83	4	U-nut
33	1	Motor Hood	84	2	Caution Decal
34	3	Hood Clip	85	1	Upright
35	1	Hood Foam, Left	86	2	Fan Screw
36	1	Upper Clevis Pin	87	4	Extension Leg Bolt
37	2	Cotter Pin	88	2	Front Wheel Bolt
38	1	Front Roller Adjustment Bolt	89	2	Front Wheel
39	4	Rear Foot Nut	90	1	Hood Cover
40	1	Incline Motor	91	5	Hood Cover Screw
41	1	Incline Motor Pin, Lower	92	1	Knob Insert
42	1	Transformer	93	1	iFIT Cable
43	1	Controller	94	1	Lift Frame
44	6	3/4" Screw	95	1	Access Door
45	1	Belly Pan	96	2	Cable Nut
46	1	Static Decal	97	2	Extension Leg
47	1	Power Cord Assembly	98	1	Console Base
48	1	Incline Wire Harness	99	14	Screw
49	1	Allen Wrench	100	1	Console Fan
50	1	Tie Holder	101	6	Plastic Spacer
51	1	Releasable Tie	102	1	Idler Pulley Nut

Key No.	Qty.	Description	Key No.	Qty.	Description
103	1	Key/Clip	114	1	Shock
104	1	Outlet Bracket Screw	115	1	TV Cable
105	1	Console	#	1	12" Blue Wire, 2F
106	4	Extension Leg Nut	#	1	8" Blue Wire, M/F
107	4	Wheel Spacer	#	1	8" Green Wire, F/Ring
108	2	Shock Clip	#	1	4" Red Wire, M/F
109	4	Isolator Screw/Roller Bracket Screw	#	1	User's Manual
110	1	Frame Ground Wire			
111	2	Rear Roller Bracket	#These parts are not illustrated		
112	1	Idler Pulley Washer	Specifications are subject to change without notice.		
113	2	Lift Frame Nut			

ORDERING REPLACEMENT PARTS

To order replacement parts, see the front cover of this manual. When ordering parts, please be prepared to provide the following information:

- the MODEL NUMBER of the product (NTL14905.3)
- the NAME of the product (NordicTrack C2800 treadmill)
- the SERIAL NUMBER of the product (see the front cover of this manual)
- the KEY NUMBER and DESCRIPTION of the part(s) (see the PART LIST on pages 38 and 39 and the EXPLODED DRAWING attached in the center of this manual)

EXPLODED DRAWING—Model No. NTL14905.3

R0306A

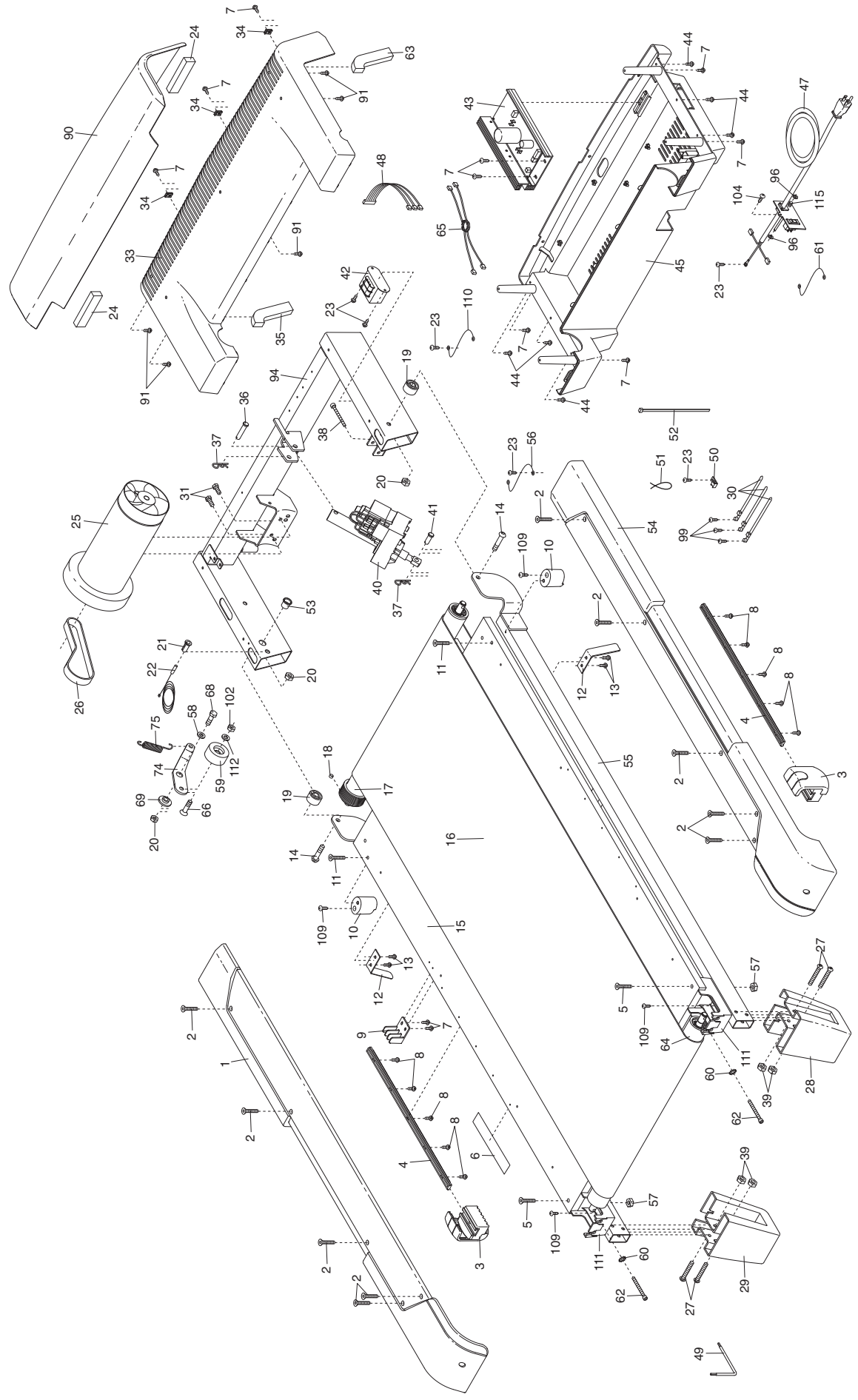

EXPLODED DRAWING—Model No. NTL14905.3

R0306A

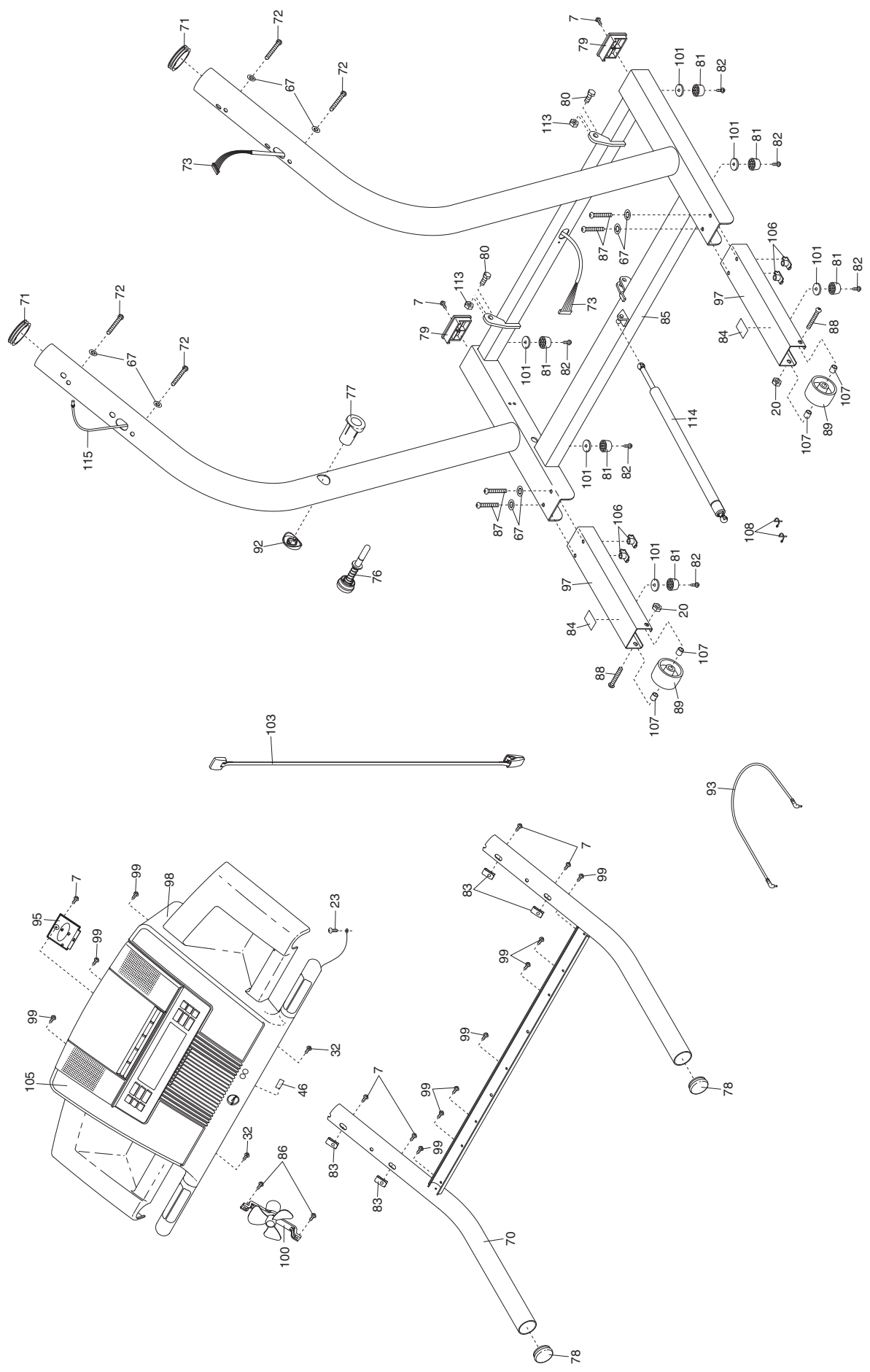

LIMITED WARRANTY

WHAT IS COVERED—The entire NordicTrack VIEWPOINT 2800 treadmill (“Product”) is warranted to be free of all defects in material and workmanship.

WHO IS COVERED—The original purchaser or any person receiving the Product as a gift from the original purchaser.

HOW LONG IS IT COVERED—ICON Health & Fitness, Inc. (“ICON”), warrants the drive motor for life. Parts and labor are warranted for one year from the date of purchase.

WHAT WE DO TO CORRECT COVERED DEFECTS—We will ship to you, without charge, any replacement part or component, providing the repairs are authorized by ICON first and are performed by an ICON trained and authorized service provider, or, at our option, we will replace the Product.

WHAT IS NOT COVERED—Any failures or damage caused by unauthorized service, misuse, accident, negligence, improper assembly or installation, alterations, modifications without our written authorization or by failure on your part to use, operate, and maintain as set out in your User’s Manual (“Manual”). This warranty does not extend to products used for commercial or rental purposes.

WHAT YOU MUST DO—Always retain proof of purchase, such as your bill of sale; store, operate, and maintain the Product as specified in the Manual; notify our Customer Service Department of any defect within 10 days after discovery of the defect; as instructed, return any defected part for replacement or, if necessary, the entire product, for repair.

USER’S MANUAL—It is VERY IMPORTANT THAT YOU READ THE MANUAL before operating the Product. Remember to do the periodic maintenance requirements specified in the Manual to assure proper operation and your continued satisfaction.

HOW TO GET PARTS AND SERVICE—Simply call our Customer Service Department at 1-888-825-2588 and tell them your name and address and the serial number of your Product. They will tell you how to get a part replaced, or if necessary, arrange for service where your Product is located or advise you how to ship the Product for service. Before shipping, always obtain a Return Authorization Number (RA No.) from our Customer Service Department; securely pack your Product (save the original shipping carton if possible); put the RA No. on the outside of the carton and insure the product. Include a letter explaining the product or problem and a copy of your proof of purchase if you believe the service is covered by warranty.

ICON is not responsible or liable for indirect, special or consequential damages arising out of or in connection with the use or performance of the product or damages with respect to any economic loss, loss of property, loss of revenues or profits, loss of enjoyment or use, costs of removal, installation or other consequential damages of whatsoever nature. Some states do not allow the exclusion or limitation of incidental or consequential damages. Accordingly, the above limitation may not apply to you.

The warranty extended hereunder is in lieu of any and all other warranties and any implied warranties of merchantability or fitness for a particular purpose is limited in its scope and duration to the terms set forth herein. Some states do not allow limitations on how long an implied warranty lasts. Accordingly, the above limitation may not apply to you.

No one is authorized to change, modify or extend the terms of this limited warranty.

This warranty gives you specific legal rights and you may have other rights which vary from state to state.

ICON HEALTH & FITNESS, INC., 1500 S. 1000 W., LOGAN, UT 84321-9813